

REVISION CHANGE:

This manual revision contains theories of operation, schematics, board layouts, and troubleshooting flowcharts for Professional Series radios with the following boards installed:

UHF (403 - 470 MHz) Main Board	PCB No. 8486458Z02*
UHF Band 2 (450 - 527 MHz) Main Board	PCB No. 8486686Z01*
VHF (136 - 174 MHz) Main Board	PCB No. 8486473Z03*
<i>* Indicates parts that cannot be ordered.</i>	

Use the information provided in this manual revision to supplement your Professional Series Two-Way Portable Radios Detailed Service Manual, Motorola publication part number 6881088C46-E.

NOTE: Radio model charts and specifications information can be found in the appropriate Basic Service Manual for the radio model you are servicing.

Publication Title	Part number
HT1250•LS Professional Series Two-Way Radio Basic Service Manual	6864110R15



This page intentionally left blank.

Table of Contents

REVISION CHANGE:.....	1
Chapter 1 UHF Theory of Operation	7
1.1 Transmitter.....	7
1.1.1 General.....	7
1.1.2 Power Amplifier.....	7
1.1.3 Antenna Switch.....	8
1.1.4 Harmonic Filter	8
1.1.5 Antenna Matching Network.....	8
1.1.6 Power Control Integrated Circuit (PCIC).....	8
1.2 Receiver.....	9
1.2.1 Receiver Front-End.....	9
1.2.2 Receiver Back-End	10
1.3 Frequency Generation Circuitry.....	10
1.4 Synthesizer	11
1.5 Voltage-Controlled Oscillator (VCO).....	12
Chapter 2 UHF Circuit Board Layouts, Schematic Diagrams and Parts List.....	15
2.1 Notes for All Schematics and Circuit Boards	15
2.2 Circuit Board/Schematic Diagrams and Parts List.....	17
Chapter 3 UHF Troubleshooting Charts.....	31
3.1 Troubleshooting Flow Chart for Controller.....	31
3.2 Troubleshooting Flow Chart for Receiver (Sheet 1 of 2)	32
3.3 Troubleshooting Flow Chart for Receiver (Sheet 2 of 2)	33
3.4 Troubleshooting Flow Chart for Transmitter	34
3.5 Troubleshooting Flow Chart for Synthesizer.....	35
3.6 Troubleshooting Flow Chart for VCO.....	36
Chapter 4 UHF Band 2 Theory of Operation	37
4.1 Transmitter.....	37
4.1.1 General.....	37
4.1.2 Power Amplifier.....	37
4.1.3 Antenna Switch.....	38
4.1.4 Harmonic Filter	38
4.1.5 Antenna Matching Network.....	38
4.1.6 Power Control Integrated Circuit (PCIC).....	38
4.2 Receiver.....	39
4.2.1 Receiver Front-End.....	39
4.2.2 Receiver Back-End	40
4.3 Frequency Generation Circuitry.....	40
4.4 Synthesizer	41
4.5 Voltage-Controlled Oscillator (VCO).....	42
Chapter 5 UHF Band 2 CB Layouts, Schematic Diagrams, and Parts List	45

5.1	Notes For All Schematics and Circuit Boards	45
5.2	Circuit Board/Schematic Diagrams and Parts List	47
Chapter 6 UHF Band 2 Troubleshooting Charts		61
6.1	Troubleshooting Flow Chart for Controller	61
6.2	Troubleshooting Flow Chart for Receiver (Sheet 1 of 2).....	62
6.3	Troubleshooting Flow Chart for Receiver (Sheet 2 of 2).....	63
6.4	Troubleshooting Flow Chart for Transmitter	64
6.5	Troubleshooting Flow Chart for Synthesizer.....	65
6.6	Troubleshooting Flow Chart for VCO.....	66
Chapter 7 VHF Theory of Operation.....		67
7.1	Transmitter.....	67
7.1.1	General	67
7.1.2	Power Amplifier	67
7.1.3	Antenna Switch	68
7.1.4	Harmonic Filter.....	68
7.1.5	Antenna Matching Network.....	68
7.1.6	Power Control Integrated Circuit (PCIC).....	68
7.2	Receiver.....	69
7.2.1	Receiver Front-End.....	69
7.2.2	Receiver Back-End	70
7.2.3	Automatic Gain Control Circuit.....	70
7.3	Frequency Generation Circuitry	71
7.4	Synthesizer	72
7.5	Voltage-Controlled Oscillator (VCO).....	73
Chapter 8 VHF Circuit Board Layouts, Schematic Diagrams and Parts List		75
8.1	Notes For All Schematics and Circuit Boards	75
8.2	Circuit Board/Schematic Diagrams and Parts List	77
Chapter 9 VHF Troubleshooting Charts		91
9.1	Troubleshooting Flow Chart for Controller	91
9.2	Troubleshooting Flow Chart for Receiver (Sheet 1 of 2).....	92
9.3	Troubleshooting Flow Chart for Transmitter	94
9.4	Troubleshooting Flow Chart for Synthesizer.....	95
9.5	Troubleshooting Flow Chart for VCO.....	96

List of Figures

Transmitter Block Diagram	7
UHF Receiver Block Diagram	9
Frequency Generation Unit Block Diagram	10
Synthesizer Block Diagram	11
VCO Block Diagram	12
UHF (403-470MHz) Main Board Top Side PCB No. 8486458Z02	17
UHF (403-470MHz) Main Board Bottom Side PCB No. 8486458Z02	18
UHF Controls And Switches Schematic Diagram	19
UHF Receiver Front-End Schematic Diagram	20
UHF Receiver Back-End Schematic Diagram	21
UHF Synthesizer Schematic Diagram	22
UHF Voltage Controlled Oscillator Schematic Diagram	23
UHF Harmonic Filter Schematic Diagram	24
UHF Transmitter Schematic Diagram	25
Controller ASFIC/ON_OFF Schematic Diagram	30
Transmitter Block Diagram	37
UHF Receiver Block Diagram	39
Frequency Generation Unit Block Diagram	40
Synthesizer Block Diagram	41
VCO Block Diagram	42
UHF Band 2 (450-527 MHz) Main Board Top Side PCB No. 8486686Z01	47
UHF Band 2 (450-527 MHz) Main Board Bottom Side PCB No. 8486686Z01	48
UHF Band 2 Controls and Switches Schematic Diagram	49
UHF Band 2 Receiver Front End Schematic Diagram	50
UHF Band 2 Receiver Back End Schematic Diagram	51
UHF Band 2 Synthesizer Schematic Diagram	52
UHF Band 2 Voltage Controlled Oscillator Schematic Diagram	53
UHF Band 2 Harmonic Filter Schematic Diagram	54
UHF Band 2 Transmitter Schematic Diagram	55
Controller ASFIC/ON_OFF Schematic Diagram	60
Transmitter Block Diagram	67
VHF Receiver Block Diagram	69
Frequency Generation Unit Block Diagram	71
Synthesizer Block Diagram	72
VCO Block Diagram	73
VHF (136-174MHz) Main Board Top Side PCB No. 8486473Z03	77
VHF (136-174MHz) Main Board Bottom Side PCB No. 8486473Z03	78
VHF Controls And Switches Schematic Diagram	79
VHF Receiver Front-End Schematic Diagram	80
VHF Receiver Back-End Schematic Diagram	81
VHF Synthesizer Schematic Diagram	82
VHF Voltage Controlled Oscillator Schematic Diagram	83
VHF Transmitter Schematic Diagram	84
Controller ASFIC/ON_OFF Schematic Diagram	90

This page intentionally left blank.

Chapter 1 UHF Theory of Operation

1.1 Transmitter

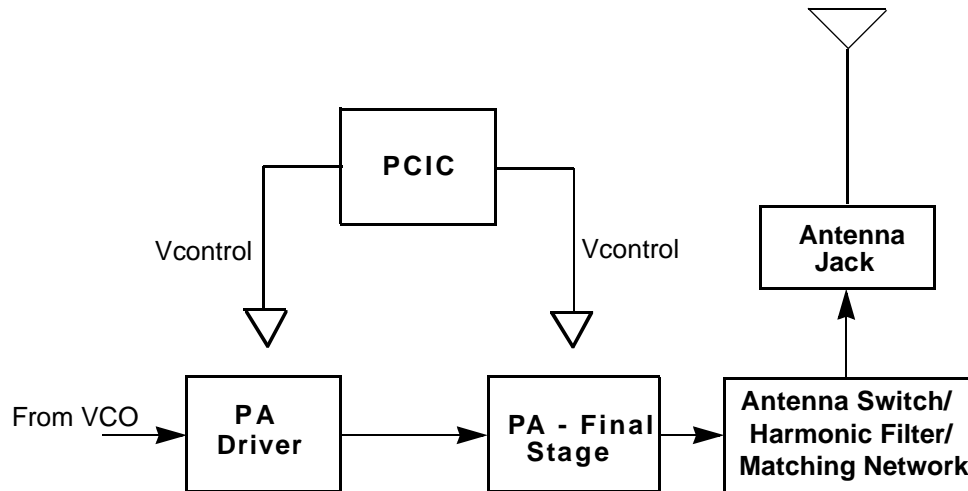

Figure 1-1. Transmitter Block Diagram

1.1.1 General

(Refer to Figure 1-1.)

The UHF transmitter contains five basic circuits:

- Power amplifier
- Antenna switch
- Harmonic filter
- Antenna matching network
- Power control integrated circuit (PCIC)

1.1.2 Power Amplifier

The power amplifier consists of two devices:

- 9Z67 LDMOS driver IC (U101)
- PRF1507 LDMOS PA (Q110)

The 9Z67 LDMOS driver IC contains a two-stage amplification with a supply voltage of 7.3V.

This RF power amplifier is capable of supplying an output power of 0.3W (pin 6 and 7) with an input signal of 2mW (3dBm) (pin16). The current drain would typically be 160mA while operating in the frequency range of 403-470 MHz.

The PRF1507 LDMOS PA is capable of supplying an output power of 7W with an input signal of 0.3W. The current drain would typically be 1300mA while operating in the frequency range of 403-470 MHz. The power output can be varied by changing the biasing voltage.

1.1.3 Antenna Switch

The antenna switch circuit consists of two PIN diodes (CR101 and CR102), a pi network (C107, L104 and C106), and two current limiting resistors (R101, R170). In the transmit mode, B+ at PCIC (U102) pin 23 will go low and turn on Q111 where a B+ bias is applied to the antenna switch circuit to bias the diodes "on." The shunt diode (CR102) shorts out the receiver port, and the pi network, which operates as a quarter wave transmission line, transforms the low impedance of the shunt diode to a high impedance at the input of the harmonic filter. In the receive mode, the diodes are both off, and hence, there exists a low attenuation path between the antenna and receiver ports.

1.1.4 Harmonic Filter

The harmonic filter consists of C104, L102, C103, L101 and C102. The design of the harmonic filter for UHF is that of a modified Zolotarev design. It has been optimized for efficiency of the power module. This type of filter has the advantage that it can give a greater attenuation in the stop-band for a given ripple level. The harmonic filter insertion loss is typically less than 1.2 dB.

1.1.5 Antenna Matching Network

A matching network which is made up of L116 is used to match the antenna's impedance to the harmonic filter. This will optimize the performance of the transmitter and receiver into an antenna.

1.1.6 Power Control Integrated Circuit (PCIC)

The transmitter uses the Power Control IC (PCIC), U102 to regulate the power output of the radio. The current to the final stage of the power module is supplied through R101, which provides a voltage proportional to the current drain. This voltage is then fed back to the Automatic Level Control (ALC) within the PCIC to regulate the output power of the transmitter.

The PCIC has internal digital to analog converters (DACs) which provide the reference voltage of the control loop. The reference voltage level is programmable through the SPI line of the PCIC.

There are resistors and integrators within the PCIC, and external capacitors (C133, C134 and C135) in controlling the transmitter rising and falling time. These are necessary in reducing the power splatter into adjacent channels.

CR105 and its associated components are part of the temperature cut-back circuitry. It senses the printed circuit board temperature around the transmitter circuits and output a DC voltage to the PCIC. If the DC voltage produced exceeds the set threshold in the PCIC, the transmitter output power will be reduced so as to reduce the transmitter temperature.

1.2 Receiver

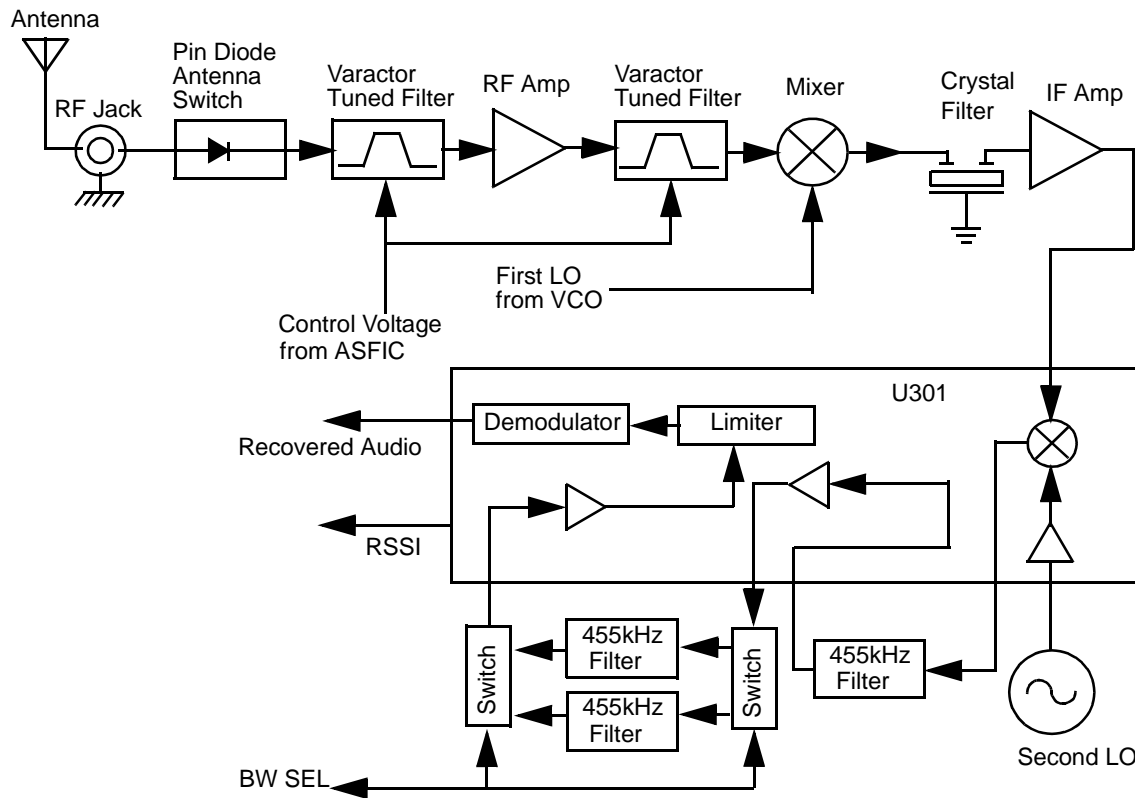

Figure 1-2. UHF Receiver Block Diagram

1.2.1 Receiver Front-End

(Refer to the *UHF Receiver Front-End Schematic Diagram* on page 20 and the *UHF Transmitter Schematic Diagram* on page 25.)

The RF signal is received by the antenna and applied to a low-pass filter. For UHF, the filter consists of L101, L102, C102, C103, C104. The filtered RF signal is passed through the antenna switch. The antenna switch circuit consists of two PIN diodes (CR101 and CR102) and a pi network (C106, L104 and C107). The signal is then applied to a varactor tuned bandpass filter. The UHF bandpass filter comprises of L301, L302, C302, C303, C304, CR301 and CR302. The bandpass filter is tuned by applying a control voltage to the varactor diodes (CR301 and CR302) in the filter.

The bandpass filter is electronically tuned by the DACRx from IC404 which is controlled by the microprocessor. Depending on the carrier frequency, the DACRx will supply the tuned voltage to the varactor diodes in the filter. Wideband operation of the filter is achieved by shifting the bandpass filter across the band.

The output of the bandpass filter is coupled to the RF amplifier transistor Q301 via C307. After being amplified by the RF amplifier, the RF signal is further filtered by a second varactor tuned bandpass filter, consisting of L306, L307, C313, C317, CR304 and CR305.

Both the pre and post-RF amplifier varactor tuned filters have similar responses. The 3 dB bandwidth of the filter is about 50 MHz. This enables the filters to be electronically controlled by using a single control voltage which is DACRx.

The output of the post-RF amplifier filter which is connected to the passive double balanced mixer consists of T301, T302 and CR306. Matching of the filter to the mixer is provided by C381. After mixing with the first LO signal from the voltage controlled oscillator (VCO) using low side injection, the RF signal is down-converted to the 44.85 MHz IF signal.

The IF signal coming out of the mixer is transferred to the crystal filter (FL301) through a resistor pad and a diplexer (C322 and L310). Matching to the input of the crystal filter is provided by C324 and L311. The crystal filter provides the necessary selectivity and intermodulation protection.

1.2.2 Receiver Back-End

(Refer to *UHF Receiver Back-End Schematic Diagram* on page 21.)

The output of crystal filter FL301 is matched to the input of first IF amplifier transistor Q302 by L330. Voltage supply to the IF amplifier is taken from the receive 5 volts (R5). The IF amplifier provides a gain of about 16dB. The amplified first IF signal is then coupled into U301 (pin 1) via C360 and L332 which provides the matching for the first IF amplifier and U301.

Within U301, the first IF 44.85 MHz signal mixes with the 44.395 MHz second local oscillator (2nd LO) to produce the second IF signal at 455 kHz. The second LO signal frequency is determined by crystal Y300. The second IF signal (455 kHz) is then filtered by an external ceramic filter FL302 before being amplified by the second IF amplifier within U301. Again, the signal is filtered by a second external ceramic filter FL303 or FL304 depending on the selected channel spacing. FL303 is used for 20/25 kHz channel spacing whereas FL304, for 12.5 kHz channel spacing. The simple circuit consisting of U302, CR312, CR313 and resistors R345, R360, R321 and R324 divert the second IF signal according to the BW_SEL line. The filtered output of the second IF signal is applied to the limiter input pin of U301.

The IF IC (U301) contains a quadrature detector using a ceramic phase-shift element (Y301) to provide audio detection. Internal amplification provides an audio output level around 120mVrms (@60% deviation) from pin 8 of U301. This demodulated audio is fed to the ASFIC_CMP IC (U404) in the controller section.

The IF IC (U301) also performs several other functions. It provides a received signal-strength indicator (RSSI) with a dynamic range of 70 dB. The RSSI is a dc voltage monitored by the microprocessor, and used as a peak indicator during the bench tuning of the receiver front-end varactor filter.

1.3 Frequency Generation Circuitry

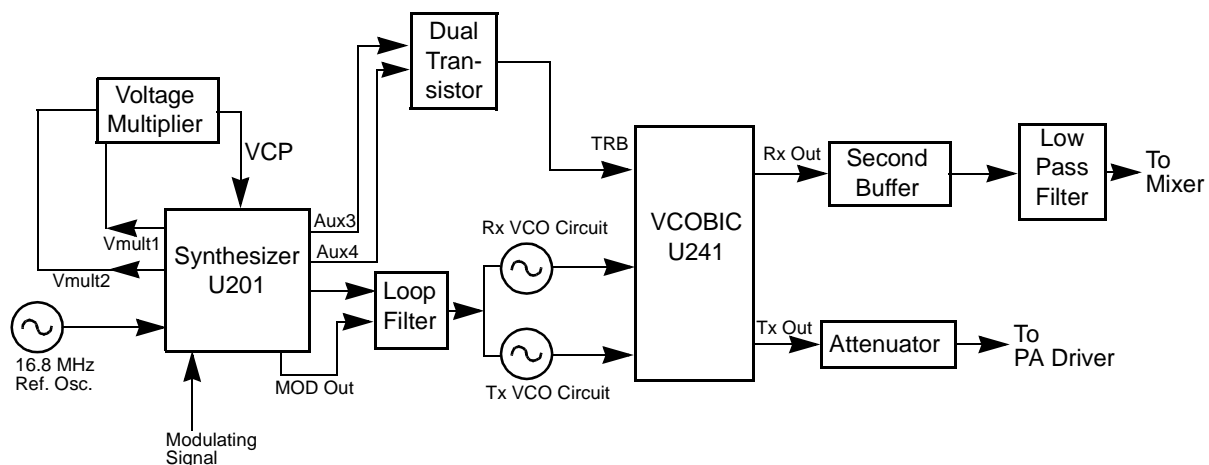

Figure 1-3. Frequency Generation Unit Block Diagram

The Frequency Generation Circuitry is composed of two main ICs:

- Fractional-N synthesizer (U201)
- VCO/Buffer IC (U241)

Designed in conjunction to maximize compatibility, the two ICs provide many of the functions that normally would require additional circuitry. The synthesizer block diagram illustrates the interconnect and support circuitry used in the region. Refer to the relevant schematics for the reference designators.

The synthesizer is powered by regulated 5V and 3.3V which come from U247 and U248 respectively. The synthesizer in turn generates a super-filtered 4.5V which powers U241.

In addition to the VCO, the synthesizer must interface with the logic and ASFIC circuitry. Programming for the synthesizer is accomplished through the data, clock and chip select lines from the microprocessor. A 3.3V dc signal from the synthesizer lock detect line indicates to the microprocessor that the synthesizer is locked.

Transmit modulation from the ASFIC is supplied to pin 10 of U201. Internally the audio is digitized by the Fractional-N and applied to the loop divider to provide the low-port modulation. The audio runs through an internal attenuator for modulation balancing purposes before going out to the VCO.

1.4 Synthesizer

(Refer to *UHF Synthesizer Schematic Diagram* on page 22.)

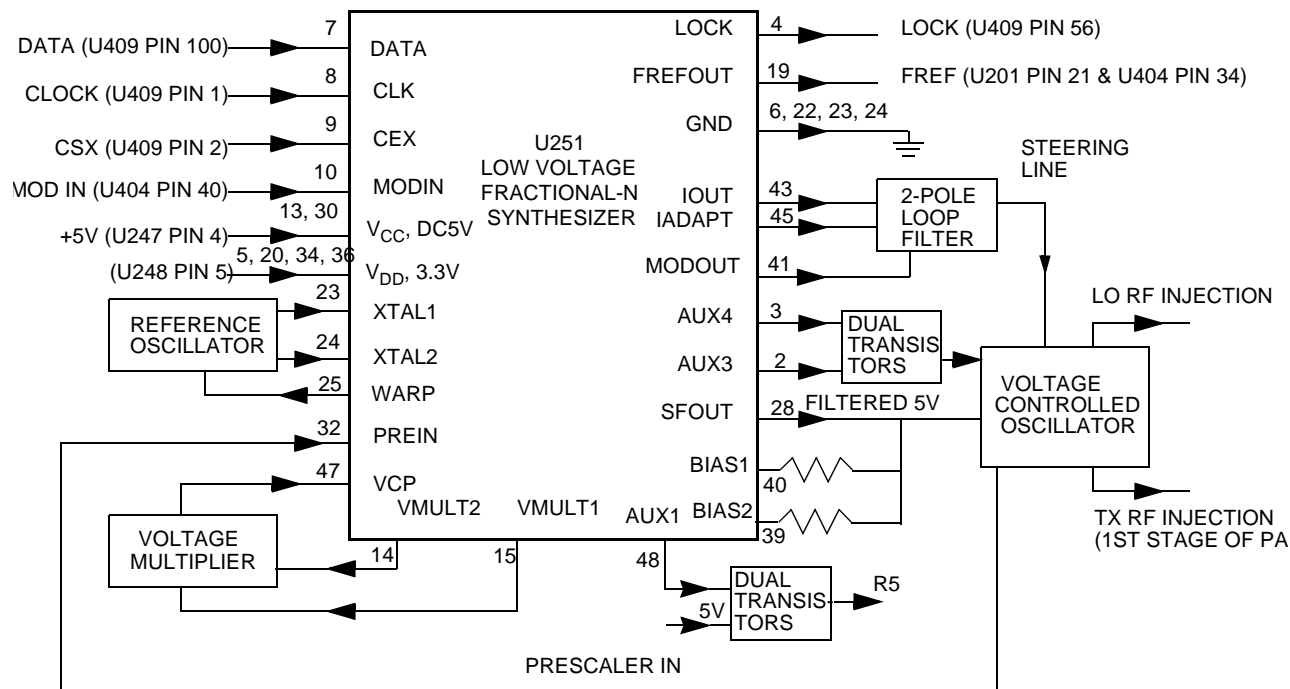

Figure 1-4. Synthesizer Block Diagram

The Fractional-N Synthesizer uses a 16.8MHz crystal (FL201) to provide a reference for the system. The LVFractN IC (U201) further divides this to 2.1MHz, 2.225 MHz, and 2.4 MHz as reference frequencies. Together with C206, C207, C208, R204 and CR203, they build up the reference oscillator which is capable of 2.5ppm stability over temperatures of -30 to 85°C. It also provides 16.8 MHz at pin 19 of U201 to be used by the ASFIC.

The loop filter which consist of C231, C232, C233, R231, R232 and R233 provides the necessary dc steering voltage for the VCO and determines the amount of noise and spur passing through.

In achieving fast locking for the synthesizer, an internal adapt charge pump provides higher current at pin 45 of U201 to put synthesizer within the lock range. The required frequency is then locked by normal mode charge pump at pin 43.

Both the normal and adapt charge pumps get their supply from the capacitive voltage multiplier which is made up of C258, C259, C228, triple diode CR201 and level shifters U210 and U211. Two 3.3V square waves (180 degrees out of phase) are first shifted to 5V, then along with regulated 5V, put through arrays of diodes and capacitors to build up 13.3V at pin 47 of U201.

1.5 Voltage-Controlled Oscillator (VCO)

(Refer to the *UHF Voltage-Controlled Oscillator Schematic Diagram* on page 23.)

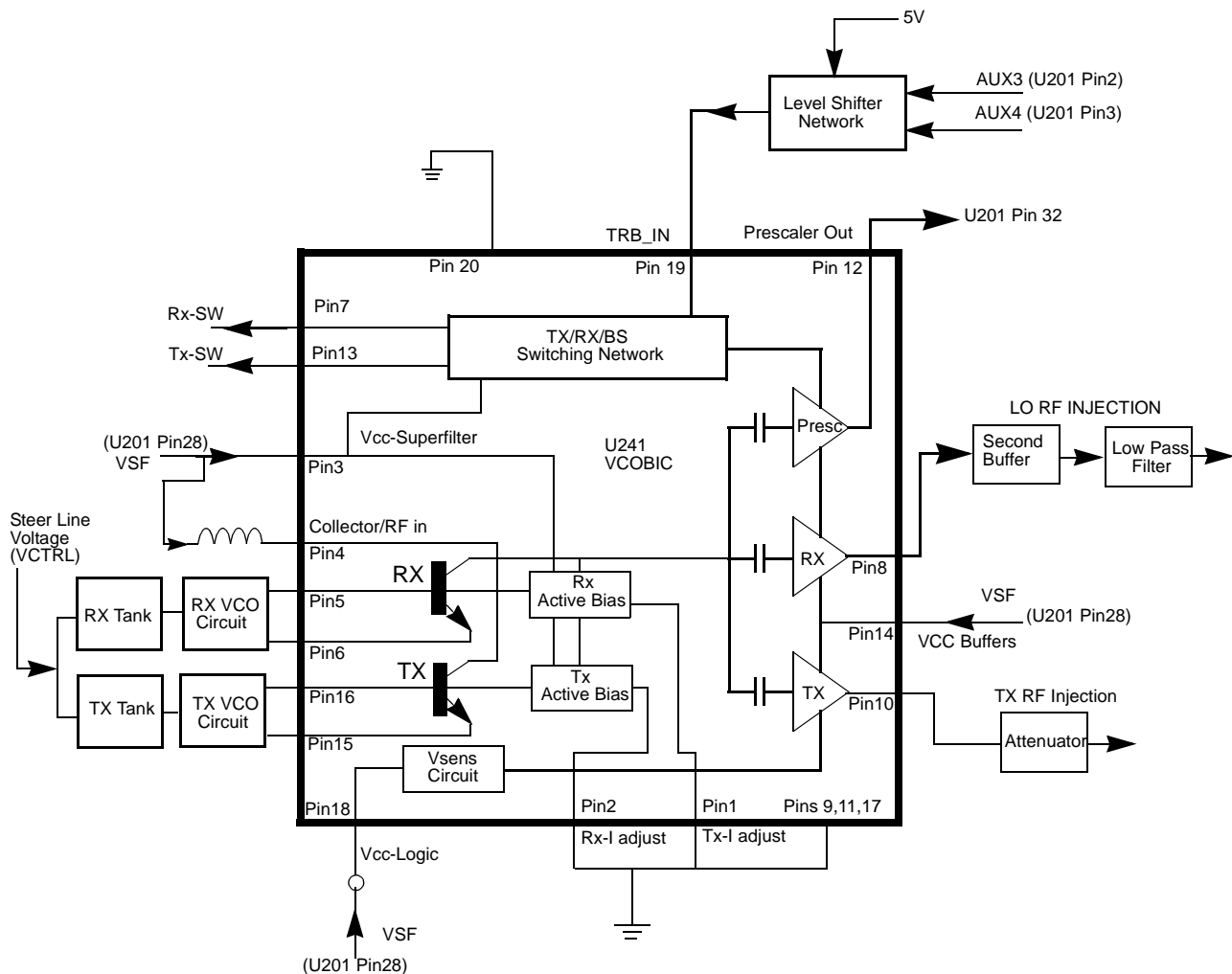

Figure 1-5. VCO Block Diagram

The VCOBIC (U241) in conjunction with the Fractional-N synthesizer (U201) generates RF in both the receive and the transmit modes of operation. The TRB line (U241 pin 19) determines which oscillator and buffer will be enabled. A sample of the RF signal from the enabled oscillator is routed from U241 pin 12, through a low pass filter, to the prescaler input (U201 pin 32). After frequency comparison in the synthesizer, a resultant CONTROL VOLTAGE is received at the VCO. This voltage is a dc voltage between 3.5V and 9.5V when the PLL is locked on frequency.

The VCOBIC (U241) is operated at 4.54V (VSF) and Fractional-N synthesizer (U201) at 3.3V. This difference in operating voltage requires a level shifter consisting of Q260 and Q261 on the TRB line.

The operation logic is shown in Table 1-1.

Table 1-1. Level Shifter Logic

Desired Mode	AUX 4	AUX 3	TRB
Tx	Low	High (@3.2V)	High (@4.8V)
Rx	High	Low	Low
Battery Saver	Low	Low	Hi-Z/Float (@2.5V)

In receive mode, U241 pin 19 is low or grounded. This activates the receive VCO by enabling the receive oscillator and the receive buffer of U241. The RF signal at U241 pin 8 is run through a second buffer to improve mixer to receive VCO isolation. The resulting RF signal is LO RF INJECTION and it is applied to the mixer at T302. (Refer to the *UHF Receiver Front-End Schematic Diagram* on page 20.)

During the transmit condition, when PTT is depressed, a five-volt current is applied to U241 pin 19. This activates the transmit VCO by enabling the transmit oscillator and the transmit buffer of U241. The RF signal at U241 pin 10 is injected into the input of the PA module (U101 pin16). This RF signal is the TX RF INJECTION. Also in transmit mode, the audio signal to be frequency modulated onto the carrier is received through the U201 pin 41.

When a high impedance is applied to U241 pin 19, the VCO is operating in BATTERY SAVER mode. In this case, both the receive and transmit oscillators as well as the receive transmit and prescaler buffer are turned off.

This page intentionally left blank.

Chapter 2 UHF Circuit Board Layouts, Schematic Diagrams and Parts List

2.1 Notes for All Schematics and Circuit Boards

* Component is frequency sensitive. Refer to the Electrical Parts List for value and usage.

1. Unless otherwise stated, resistances are in Ohms ($k = 1000$), and capacitances are in picofarads (pF) or microfarads (μF).
2. DC voltages are measured from point indicated to chassis ground using a Motorola DC multimeter or equivalent. Transmitter measurements should be made with a $1.2 \mu\text{H}$ choke in series with the voltage probe to prevent circuit loading.
3. Reference Designators are assigned in the following manner:
 - 100 Series = Transmitter
 - 200 Series = Frequency Generation
 - 300 Series = Receiver
 - 400/500 Series = Controller
 - 600 Series = Keypad board
4. Interconnect Tie Point Legend:
 - UNSWB+ = Unswitch Battery Voltage (7.5V)
 - SWB+ = Switch Battery Voltage (7.5V)
 - R5 = Receiver 5 Volts
 - CLK = Clock
 - Vdda = Regulated 3.3 Volts (for analog)
 - Vddd = Regulated 3.3 Volts (for digital)
 - CSX = Chip Select Line
 - SYN = Synthesizer
 - DACRX = Digital-to-Analog Voltage (for Receiver Front-End Filter)
 - VSF = Voltage Super Filtered (5 volts)
 - VR = Voltage Regulator

SIX-LAYER CIRCUIT BOARD DETAIL VIEWING COPPER STEPS IN PROPER LAYER SEQUENCE

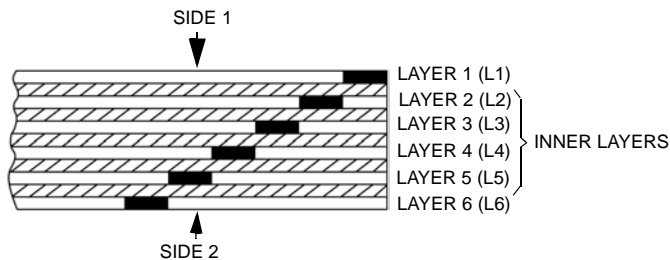

This page intentionally left blank.

2.2 Circuit Board/Schematic Diagrams and Parts List

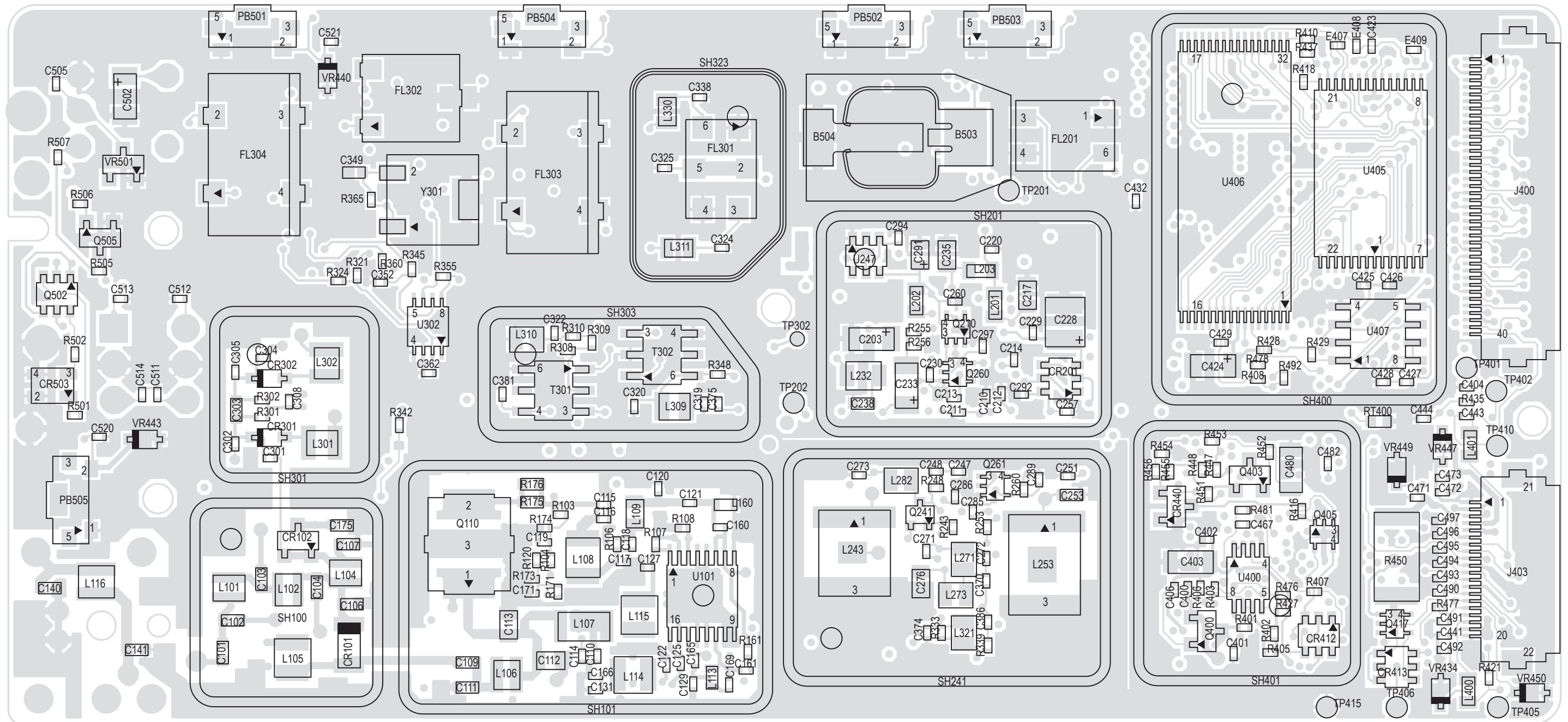

Figure 2-1. UHF (403-470MHz) Main Board Top Side PCB No. 8486458Z02

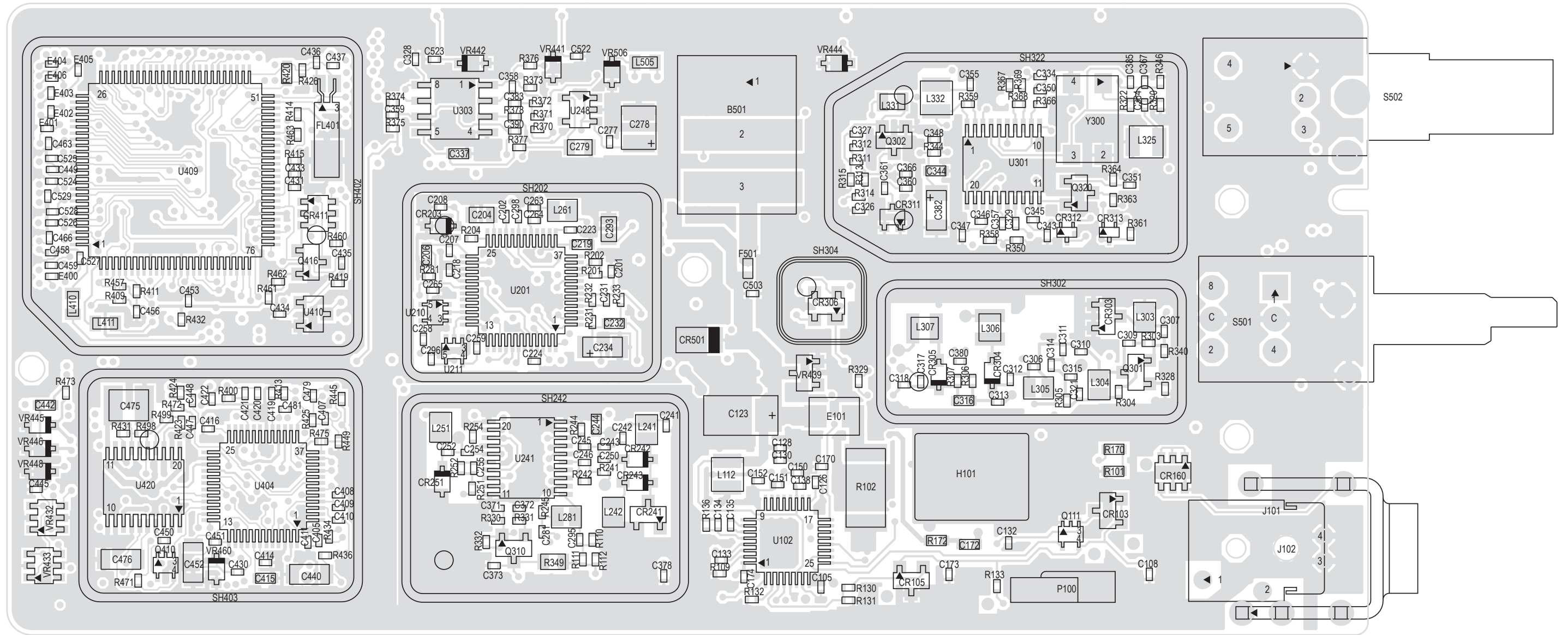

Figure 2-2. UHF (403-470MHz) Main Board Bottom Side PCB No. 8486458Z02

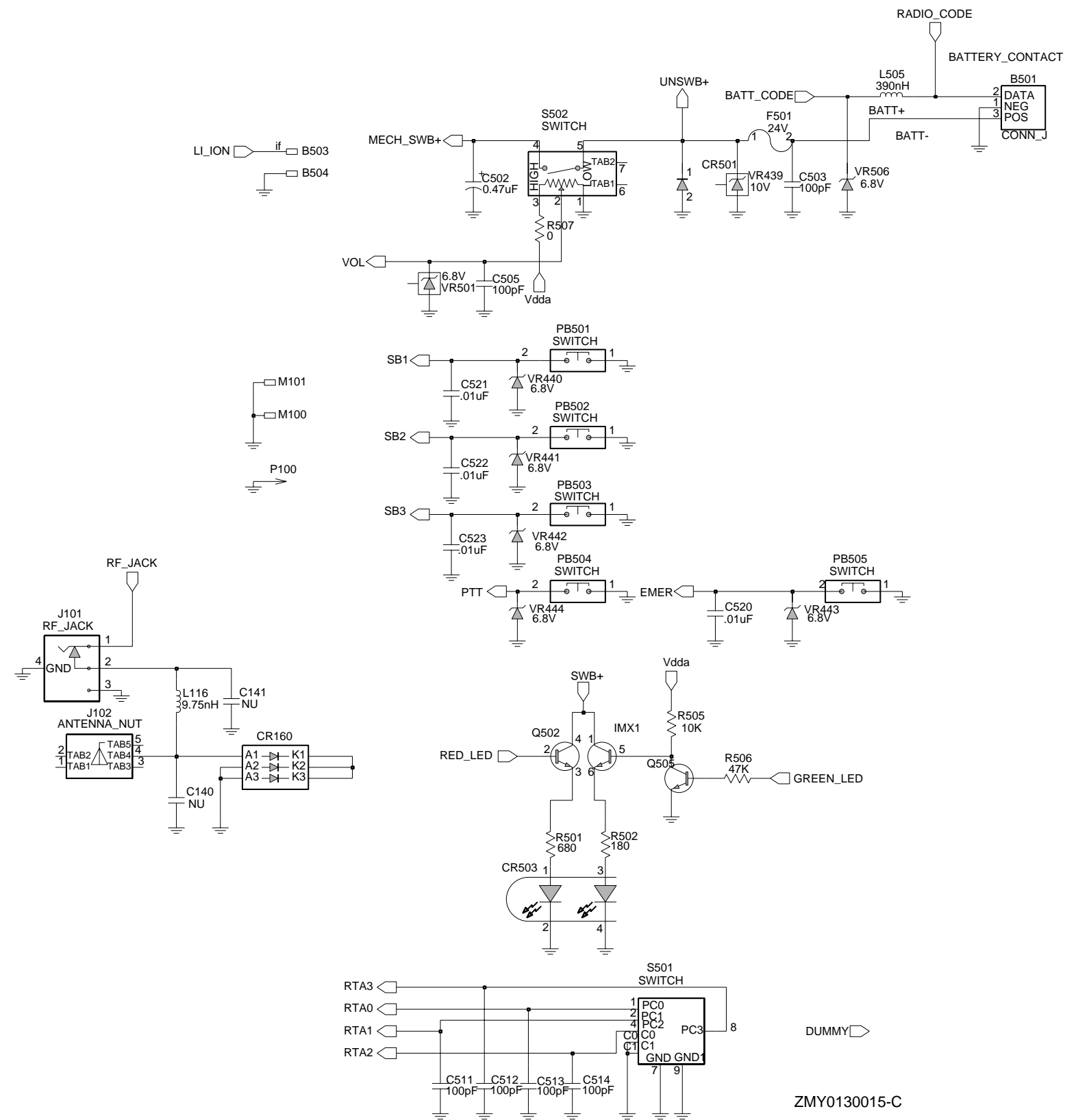

Figure 2-3. UHF Controls And Switches Schematic Diagram

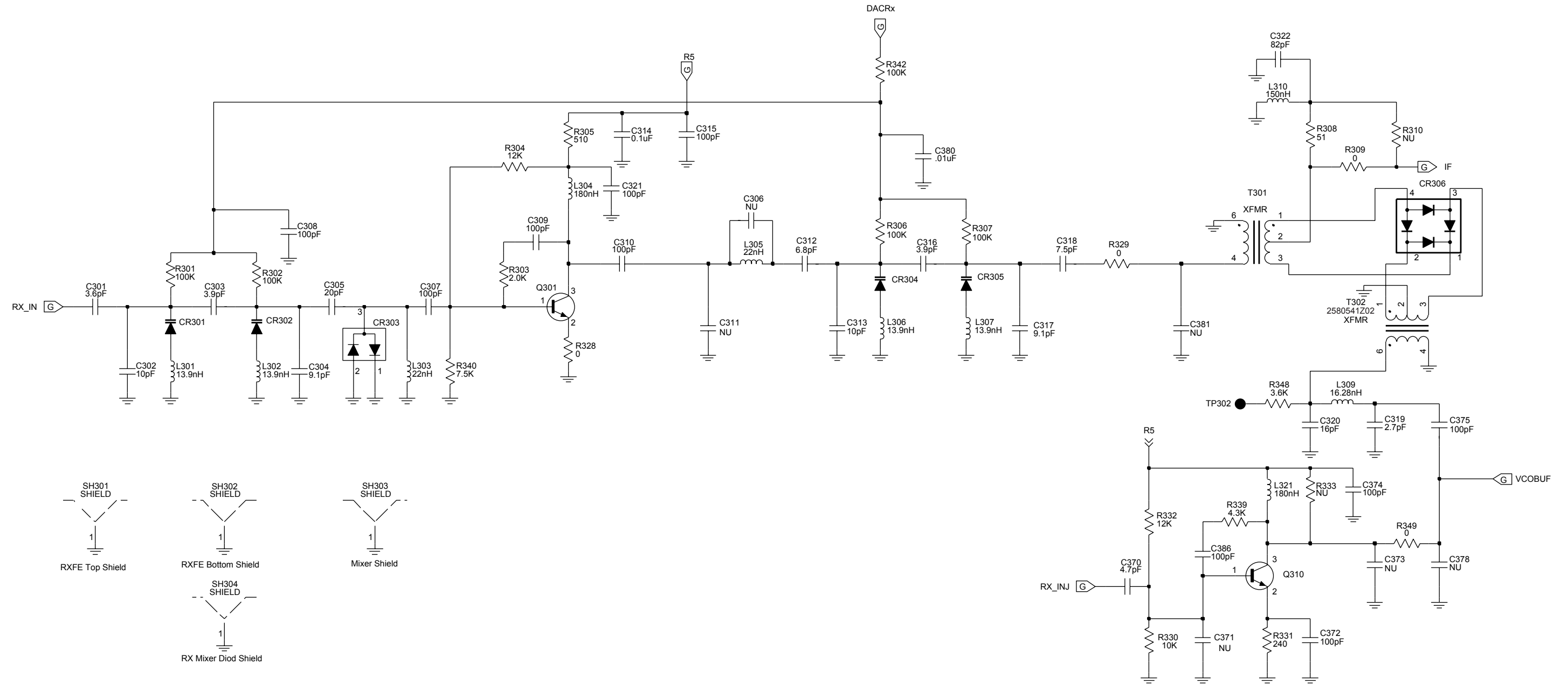

Figure 2-4. UHF Receiver Front-End Schematic Diagram

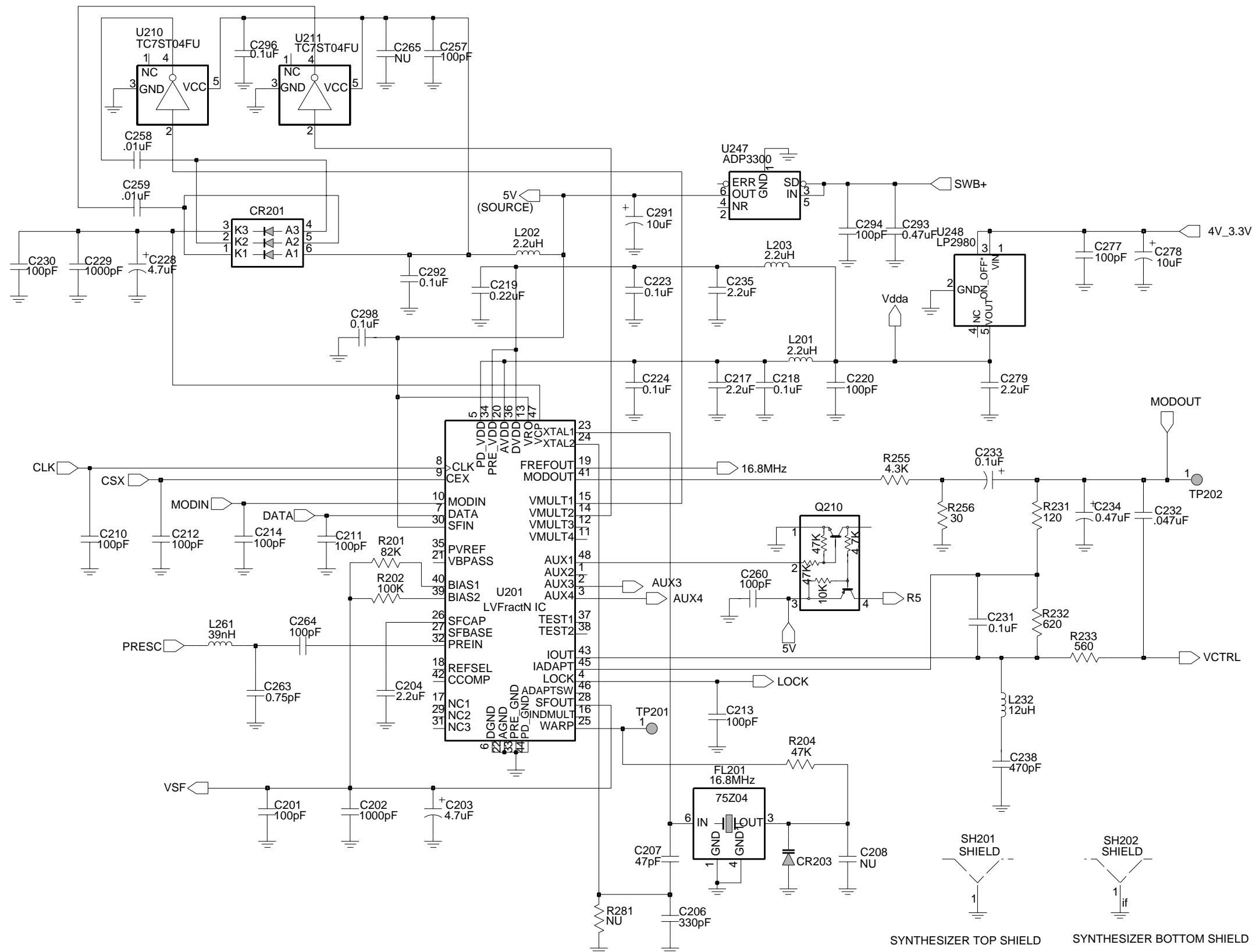

Figure 2-6. UHF Synthesizer Schematic Diagram

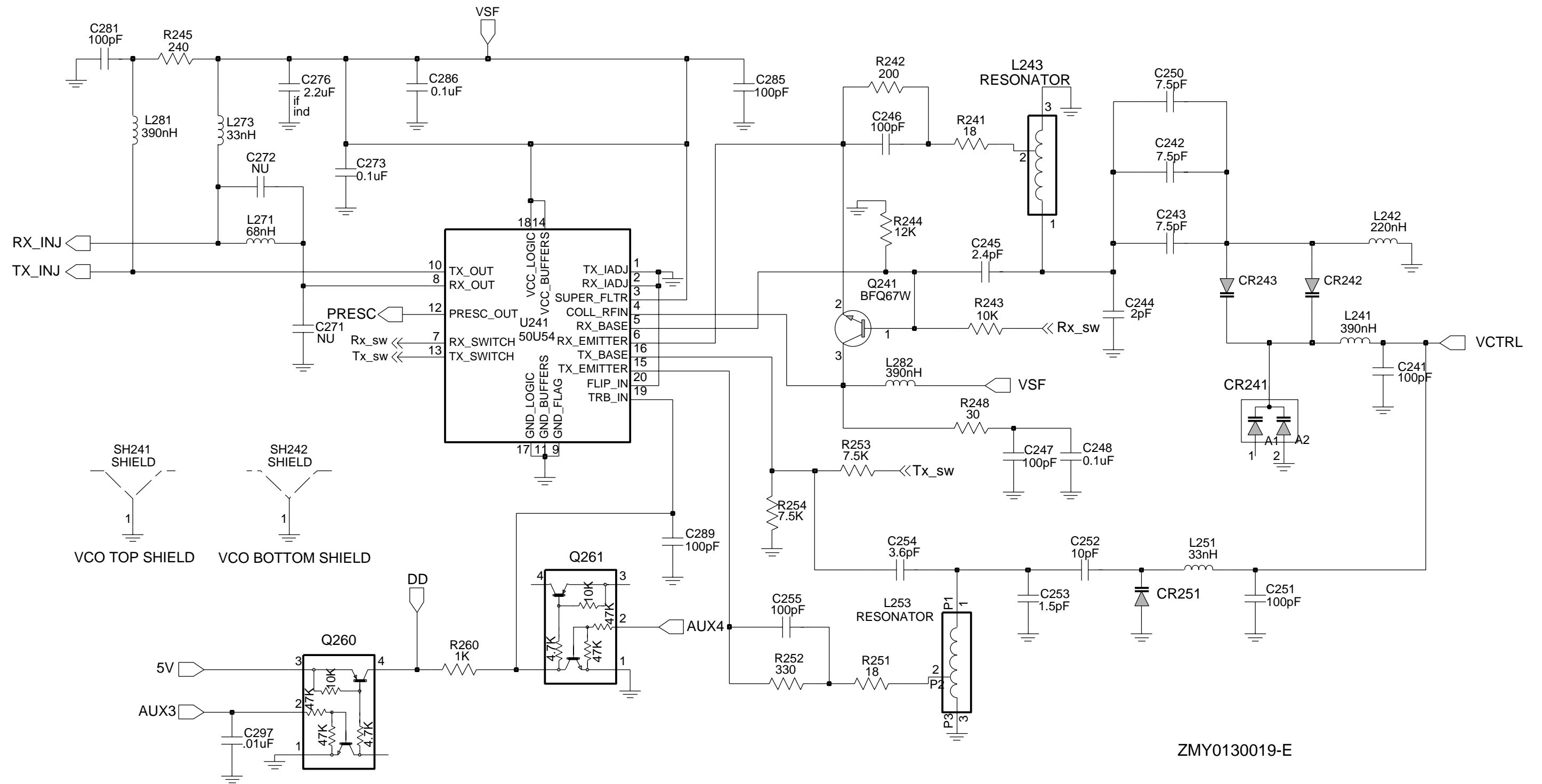
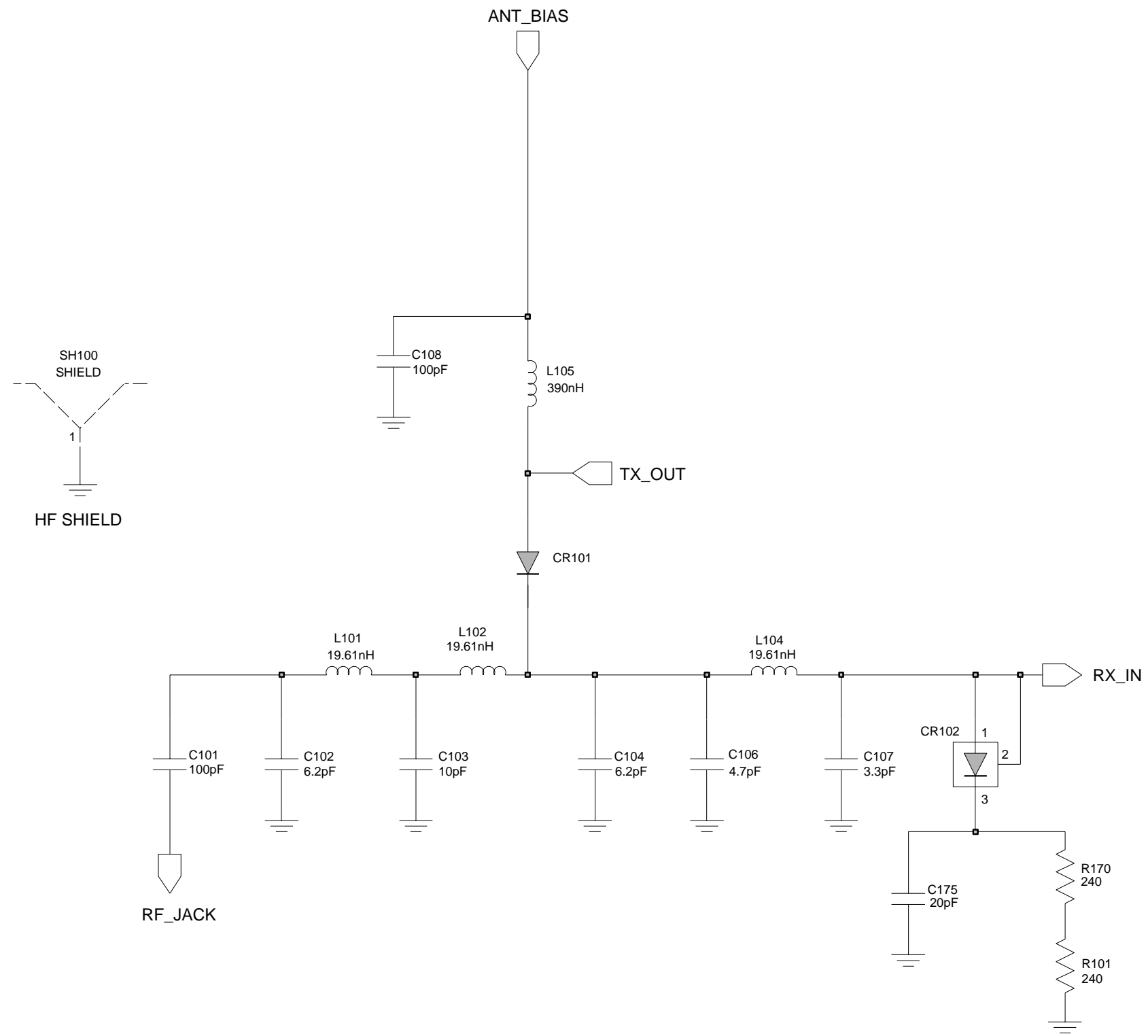

Figure 2-7. UHF Voltage Controlled Oscillator Schematic Diagram



ZMY0130486-A

Figure 2-8. UHF Harmonic Filter Schematic Diagram

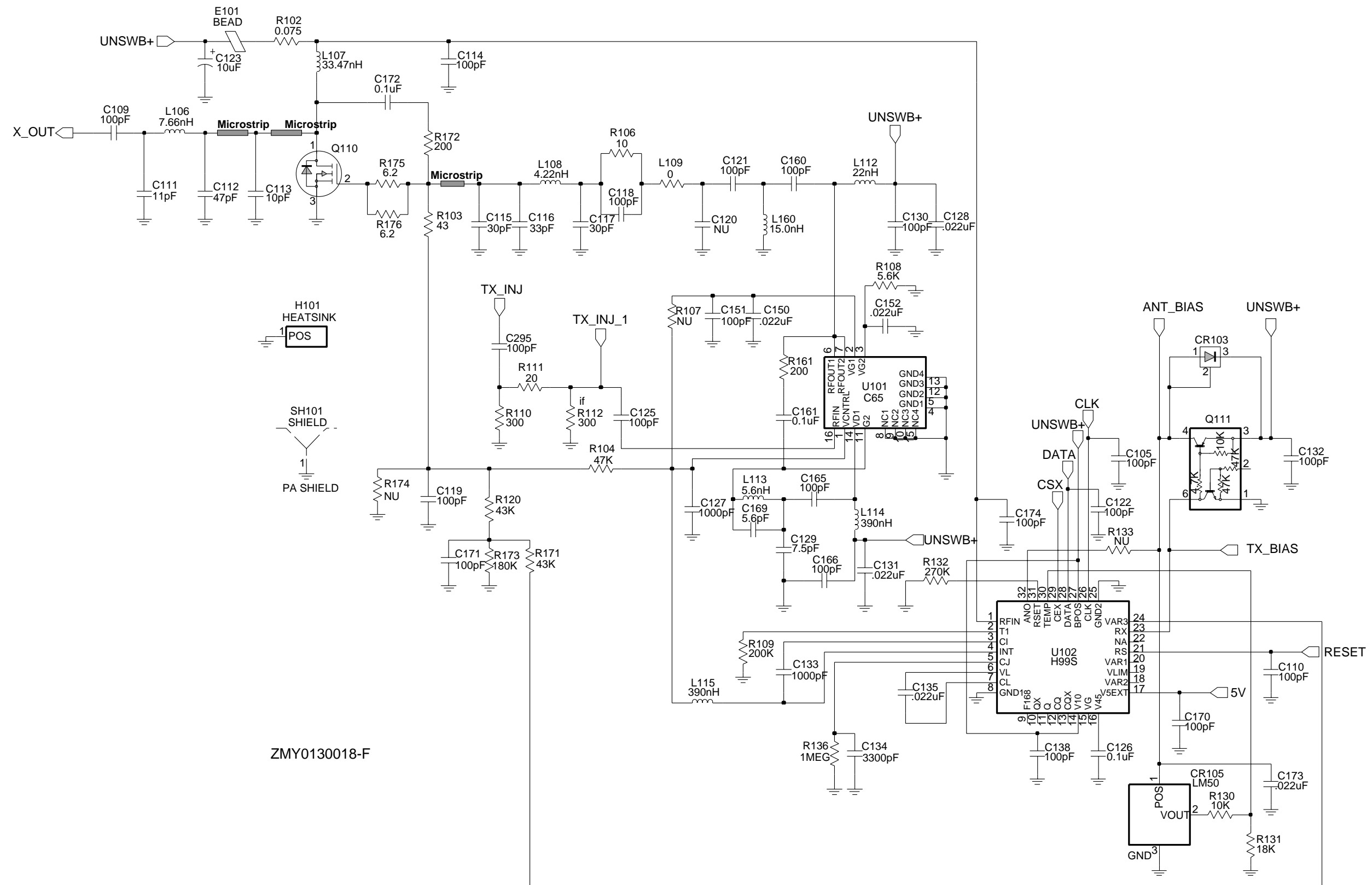

Figure 2-9. UHF Transmitter Schematic Diagram

UHF Radio Parts List

Circuit Ref	Motorola Part No.	Description
B501	0986237A02	Battery Contact Module
B503	3980502Z01	Backup battery B+
B504	3980501Z01	Backup battery B-
C101	2113740F51	100pF
C102	2113740F22	6.2pF
C103	2113740F27	10pF
C104	2113740F22	6.2pF
C105	2113743N50	100pF
C106	2113740F19	4.7pF
C107	2113740F15	3.3pF
C108	2113743N50	100pF
C109	2113740F51	100pF
C110	2113743N50	100pF
C111	2113740F31	15pF
C112	2180605Z32	47pF
C113	2180605Z16	10pF
C114	2113743N50	100pF
C115	2113743N35	24pF
C116	2113743N35	24pF
C117	2113743N34	22pF
C118	2113743N50	100pF
C119	2113743N50	100pF
C120	2113743N27	11pF
C121	2113743N50	100pF
C122	2113743N50	100pF
C123	2311049A96	33uF
C125	2113743N50	100pF
C126	2113743M24	100000pF
C127	2113743L17	1000pF
C128	2113743M08	22000pF
C129	2113743N23	7.5pF
C130	2113743N50	100pF
C131	2113743M08	22000pF
C132	2113743N50	100pF
C133	2113743L17	1000pF
C134	2113743L29	3300pF
C135	2113743M08	22000pF
C138	2113743N50	100pF
C140	0662057A67	5600
C141	NOT PLACED	
C150	2113743M08	22000pF
C151	2113743N50	100pF
C152	2113743M08	22000pF
C160	2113743N50	100pF
C161	2113743M24	100000pF
C165	2113743N50	100pF
C166	2113743N50	100pF
C169	2113743N20	5.6 pF
C170	2113743N50	100pF

Circuit Ref	Motorola Part No.	Description
C171	2113743N50	100pF
C172	2113740F51	100pF
C173	2113743M08	22000pF
C174	2113743N50	100pF
C175	2113740F51	100pF
C201	2113743N50	100pF
C202	2113743L17	1000pF
C203	2113928L05	4.7uF
C204	2104993J02	2.2uF
C206	2113740F63	330pF
C207	2113743N42	47pF
C208	NOT PLACED	
C210	2113743N50	100pF
C211	2113743N50	100pF
C212	2113743N50	100pF
C213	2113743N50	100pF
C214	2113743N50	100pF
C217	2104993J02	2.2uF
C218	2113743M24	100000pF
C219	2113743K16	0.220uF
C220	2113743N50	100pF
C223	2113743M24	100000pF
C224	2113743M24	100000pF
C228	2311049J11	4.7uF
C229	2113743L17	1000pF
C230	2113743N50	100pF
C231	2113743M24	100000pF
C232	2113743E12	0.047uF
C233	2311049A01	0.1uF
C234	2311049A05	0.47uF
C235	2104993J02	2.2uF
C238	2113741F17	470pF
C241	2113743N50	100pF
C242	2113743N23	7.5pF
C243	2113743N23	7.5pF
C244	2113740F10	2.0pF
C245	2113743N11	2.4pF
C246	2113743N50	100pF
C247	2113743N50	100pF
C248	2113743M24	100000pF
C250	2113743N23	7.5pF
C251	2113743N50	100pF
C252	2113743N26	10pF
C253	2113740F09	1.8pF
C254	2113743N15	3.6pF
C255	2113743N50	100pF
C257	2113743N50	100pF
C258	2113743L41	10000pF
C259	2113743L41	10000pF
C260	2113743N50	100pF
C263	2113743N02	0.75pF

Circuit Ref	Motorola Part No.	Description
C264	2113743N50	100pF
C265	NOT PLACED	
C271	NOT PLACED	
C272	NOT PLACED	
C273	2113743M24	100000pF
C276	2104993J02	2.2uF
C277	2113743N50	100pF
C278	2311049A57	10uF
C279	2104993J02	2.2uF
C281	2113743N50	100pF
C285	2113743N50	100pF
C286	2113743M24	100000pF
C289	2113743N50	100pF
C291	2311049A69	10uF
C292	2113743M24	100000pF
C293	2113743A27	0.470uF
C294	2113743N50	100pF
C295	2113743N50	100pF
C296	2113743M24	100000pF
C297	2113743L41	10000pF
C298	2113743M24	100000pF
C301	2113743N15	3.6pF
C302	2113743N26	10pF
C303	2113740L08	3.9pF
C304	2113743N26	10pF
C305	2113743N33	20pF
C306	NOT PLACED	
C307	2113743N50	100pF
C308	2113743N50	100pF
C309	2113743N50	100pF
C310	2113743N50	100pF
C311	NOT PLACED	
C312	2113743N25	9.1pF
C313	2113743N26	10pF
C314	2113743M24	100000pF
C315	2113743N50	100pF
C316	2113740L08	3.9pF
C317	2113743N25	9.1pF
C318	2113743N23	7.5pF
C319	2113743N12	2.7pF
C320	2113743N31	16pF
C321	2113743N50	100pF
C322	2113743N48	82pF
C324	2113743N34	22pF
C325	2109445U26	9.1pF
C326	2113743M24	0.1pF
C327	2113743M24	0.1pF
C328	2113743M24	100000pF
C329	2113743M24	100000pF
C334	2113743L33	4700pF
C337	NOT PLACED	

Circuit Ref	Motorola Part No.	Description
C338	NOT PLACED	
C343	2113743M24	100000pF
C344	2113743E20	0.1uF
C345	2113743M24	100000pF
C346	2113743M24	100000pF
C347	2113743M24	100000pF
C348	2113743M24	100000pF
C349	2113743E20	0.1uF
C350	2113743M24	100000pF
C351	2113743N52	120pF
C352	2113743M24	100000pF
C355	2113743M24	100000pF
C357	2113743M24	100000pF
C358	NOT PLACED	
C359	NOT PLACED	
C360	2113743N14	3.3pF
C361	2113743M24	100000pF
C362	2113743M24	100000pF
C364	2113743N35	24pF
C366	NOT PLACED	
C367	2113743N37	30pF
C370	2113743N18	4.7pF
C371	NOT PLACED	
C372	2113743N50	100pF
C373	NOT PLACED	
C374	2113743N50	100pF
C375	2113743N50	100pF
C378	NOT PLACED	
C380	2113743L41	10000pF
C381	NOT PLACED	
C382	2311049A59	10uF
C383	NOT PLACED	
C385	2113743N37	30pF
C386	2113743N50	100pF
C390	NOT PLACED	
C400	2113743L41	10000pF
C401	2113743M24	100000pF
C402	2113743M24	100000pF
C403	2113743G24	2.2uF
C404	NOT PLACED	
C405	2113743N50	100pF
C406	NOT PLACED	
C407	2113928N01	0.1uF
C408	2113743N50	100pF
C409	2113743M24	100000pF
C410	2113928N01	0.1uF
C411	2113743M24	100000pF
C414	2113743M24	100000pF
C415	2185895Z01	0.01uF
C416	2113928N01	0.1uF
C419	NOT PLACED	

Circuit Ref	Motorola Part No.	Description	Circuit Ref	Motorola Part No.	Description	Circuit Ref	Motorola Part No.	Description	Circuit Ref	Motorola Part No.	Description
C420	2113743L41	10000pF	C495	2113743N50	100pF	E403	2480640Z01	Ferrite bead	L303	2462587V26	22nH
C421	2113928N01	0.1uF	C496	2113743N50	100pF	E404	2480640Z01	Ferrite bead	L304	2462587V37	180nH
C422	2113743M24	100000pF	C497	2113743N50	100pF	E405	2480640Z01	Ferrite bead	L305	2462587V26	22nH
C423	2113743N50	100pF	C502	2311049A05	0.47uF	E406	2480640Z01	Ferrite bead	L306	2479990C01	13.9nH
C424	2311049A59	10uF	C503	2113743N50	100pF	E407	2480640Z01	Ferrite bead	L307	2479990C01	13.9nH
C425	2113743M24	100000pF	C505	2113743N50	100pF	E408	2480640Z01	Ferrite bead	L309	2479990C02	16.28nH
C426	2113743N50	100pF	C511	2113743N50	100pF	E409	2480640Z01	Ferrite bead	L310	2462587V36	150nH
C427	2113743N50	100pF	C512	2113743N50	100pF	F501	6580542Z01	3A fuse	L311	2413926K32	560nH
C428	2113743M24	100000pF	C513	2113743N50	100pF	FL201	4805875Z04	16.8MHz Xtal oscillator	L321	2462587V37	180nH
C429	2113743M24	100000pF	C514	2113743N50	100pF	FL301	9180022M11	Xtal Filter 44.85MHz	L325	2462587N68	1uH
C430	2113928N01	0.1uF	C520	2113743L41	10000pF	FL302	9180468V05	455kHz 4-pole ceramic filter	L330	0662057C01	0
C431	2113743N50	100pF	C521	2113743L41	10000pF	FL303	9180469V05	455kHz 6-pole ceramic filter	L331	2413926K33	680nH
C432	NOT PLACED		C522	2113743L41	10000pF	FL304	9180469V03	455kHz 6-pole ceramic filter	L332	2413923A25	1.2uH
C433	2113743L41	10000pF	C523	2113743L41	10000pF	FL401	4870368G02	Xtal Oscillator 38.4kHz	L400	2462587Q42	390nH
C434	2113928N01	0.1uF	C524	2113743N50	100pF	H101	2680499Z01	Heat spreader	L401	2462587Q42	390nH
C435	2113743M24	100000pF	C525	2113743N50	100pF	J101	0985613Z01	RF Jack	L410	2462587Q42	390nH
C436	2113743N34	22pF	C526	2113743N50	100pF	J102	0280519Z04	Nut, Antenna	L411	2462587Q42	390nH
C437	2113743N34	22pF	C527	2113743N50	100pF	J400	0905505Y04	40-pin connector	L505	2462587Q42	390nH
C440	2113743G26	4.7F	C528	2113743N50	100pF	J403	0905505Y02	20-pin connector	P100	3905643V01	Ground contact finger
C441	2113743N50	100pF	C529	2113743N50	100pF	L101	2479990B02	19.61nH	PB501	4086470Z01	Tactile switch, pushbutton
C442	2113743E20	0.10uF	CR101	4880973Z02	Pin diode	L102	2479990B02	19.61nH	PB502	4086470Z01	Tactile switch, pushbutton
C443	2113928N01	0.1uF	CR102	4802245J41	Pin diode	L104	2479990B02	19.61nH	PB503	4086470Z01	Tactile switch, pushbutton
C444	2113743N50	100pF	CR103	4802245J41	Pin diode	L105	2462587N22	390nH	PB504	4086470Z01	Tactile switch, pushbutton
C445	2113743N50	100pF	CR105	5185963A15	Temperature sensor	L106	2479990A02	7.66nH	PB505	4086470Z01	Tactile switch, pushbutton
C447	2113743M08	22000pF	CR160	NOT PLACED		L107	2479990G01	33.47nH	Q110	4813828A09	RF PA
C448	2113928N01	0.1uF	CR201	4802233J09	Triple diode (SOT 25)	L108	2479990A01	4.22nH	Q111	4809939C05	TSTR Dual NPN/PNP UMH 5
C449	2113743N50	100pF	CR203	4862824C03	Varactor	L109	2479990B01	11.03nH	Q210	4809939C05	TSTR Dual NPN/PNP UMH 5
C450	NOT PLACED		CR241	4805649Q13	Varactor	L112	2462587N45	22nH	Q241	4805218N63	RF NPN transistor
C451	2113743M08	22000pF	CR242	4862824C08	Varactor	L113	2413926H09	5.6nH	Q260	4809939C05	TSTR Dual NPN/PNP UMH 5
C452	2113743B29	1uF	CR243	4862824C08	Varactor	L114	2462587N45	22nH	Q261	4809939C05	TSTR Dual NPN/PNP UMH 5
C453	2113743N50	100pF	CR251	4802245J22	Varactor	L115	2462587N22	390nH	Q301	4802245J44	NPN Transistor
C456	2113743N50	100pF	CR301	4862824C08	Varactor	L116	2479990A03	9.75nH	Q302	4802197J95	NPN Transistor
C458	2113743N50	100pF	CR302	4862824C08	Varactor	L160	2413926H14	15nH	Q310	4802245J44	NPN Transistor
C459	2113743N50	100pF	CR303	4880154K03	Dual common anode-cathode diode	L201	2462587Q20	2200nH	Q320	4813824A10	RF NPN transistor
C463	2113743N50	100pF	CR304	4862824C08	Varactor	L202	2462587Q20	2200nH	Q400	4809579E18	Mosfet P - channel
C466	2113743N50	100pF	CR305	4862824C08	Varactor	L203	2462587Q20	2200nH	Q403	4813824A17	Bipolar Transistor, PNP
C467	2113928N01	0.1uF	CR306	4802245J42	Ring Quad diode (SOT-143)	L232	2462587P25	12000nH	Q405	4802245J54	Dual NPN Transistor
C471	2113743N50	100pF	CR311	4813825A19	Diode Schottky	L241	2462587V41	390nH	Q410	4802245J54	Dual NPN Transistor
C472	2113743L09	470pF	CR312	4802245J97	Switch Diode	L242	2462587V38	220nH	Q416	4809579E18	Mosfet P - channel
C473	2113743L09	470pF	CR313	4802245J97	Switch Diode	L243	2485776Z01	Multi-layered Teflon resonator, Rx	Q417	4809939C05	TSTR Dual NPN/PNP UMH 5
C475	2113743H14	10uF	CR411	4802245J62	Diode Schottky	L251	2462587V28	33nH	Q502	5180159R01	DUAL TRANS NPNS
C476	2113928D08	10uF	CR412	4802245J62	Diode Schottky	L253	2460593C02	Multi-layered Teflon resonator, Tx	Q505	4880214G02	NPN
C479	2113928N01	0.1uF	CR413	4802245J62	Diode Schottky	L261	2462587V29	39nH	R101	0662057A34	240
C480	2113928D08	10uF	CR440	4813833C02	Dual common cathode diode	L271	2462587V32	68nH	R102	0680539Z01	0.1
C481	2113928N01	0.1uF	CR501	4880107R01	Rectifier	L273	2462587V28	33nH	R103	0662057M41	43
C482	2113928N01	0.1uF	CR503	4805729G49	LED Red/Yellow	L281	2462587V41	390nH	R104	0662057N15	47k
C490	2113743N50	100pF	E101	2484657R01	Ferrite bead	L282	2462587V41	390nH	R106	0662057M26	10
C491	2113743N50	100pF	E400	2480640Z01	Ferrite bead	L301	2479990C01	13.9nH	R107	NOT PLACED	
C492	2113743N50	100pF	E401	2480640Z01	Ferrite bead	L302	2479990C01	13.9nH	R108	0662057M92	5600
C493	2113743N50	100pF	E402	2480640Z01	Ferrite bead				R109	0662057N30	200k
C494	2113743N50	100pF							R110	0662057M61	300

Circuit Ref	Motorola Part No.	Description
R111	0662057M33	20
R112	0662057M61	300
R120	0662057N14	43k
R130	0662057M98	10k
R131	0662057N05	18k
R132	0662057N33	270k
R133	NOT PLACED	
R136	NOT PLACED	
R161	0662057M57	200
R170	0662057A34	240
R171	0662057N14	43k
R172	0662057A32	200
R173	0662057N29	180k
R174	0662057N15	47k
R175	0662057B59	3.0
R176	0662057B59	3.0
R201	0662057N21	82k
R202	0662057N23	100k
R204	0662057N15	47k
R231	0662057M52	120
R232	0662057M69	620
R233	0662057M68	560
R241	0662057M32	18
R242	0662057M57	200
R243	0662057M98	10k
R244	0662057N01	12k
R245	0662057M59	240
R248	0662057M37	30
R251	0662057M32	18
R252	0662057M62	330
R253	0662057M95	7500
R254	0662057M95	7500
R255	0662057M89	4300
R256	0662057M37	30
R260	0662057M74	1000
R281	NOT PLACED	
R301	0662057N23	100k
R302	0662057N23	100k
R303	0662057M81	2K
R304	0662057N01	12k
R305	0662057M67	510
R306	0662057N23	100k
R307	0662057N23	100k
R308	0662057M43	51
R309	0662057M01	0
R310	NOT PLACED	
R311	0662057N11	33k
R312	0662057M90	4.7K
R313	0662057M62	330
R314	0662057M79	1600
R315	0662057N01	12k

Circuit Ref	Motorola Part No.	Description
R320	NOT PLACED	
R321	0662057N13	39K
R322	0662057M74	1000
R324	0662057N06	20K
R328	0662057M01	0
R329	0662057M01	0
R330	0662057M98	10K
R331	0662057M57	200
R332	0662057N01	12K
R333	NOT PLACED	
R339	0662057M89	4.3K
R340	0662057M95	7.5K
R342	0662057N23	100k
R344	0662057M43	51
R345	0662057N13	39k
R346	0662057N03	15k
R348	0662057M87	3600
R349	0662057C01	0
R350	0662057M86	3300
R355	0662057N23	100k
R358	0662057M83	2400
R359	NOT PLACED	
R360	0662057N06	20k
R361	0662057N06	20k
R363	0662057M64	390
R364	0662057M80	1800
R365	0662057M76	1200
R366	0662057N01	12k
R367	0662057V04	12k
R368	0662057V02	10k
R369	0662057M70	680
R370	0662057M01	0
R371	NOT PLACED	
R372	NOT PLACED	
R373	NOT PLACED	
R374	NOT PLACED	
R375	NOT PLACED	
R376	NOT PLACED	
R377	NOT PLACED	
R378	NOT PLACED	
R400	0662057N15	47k
R401	0662057M01	0
R402	NOT PLACED	
R403	NOT PLACED	
R405	0662057M01	0
R406	0662057N20	75k
R407	0662057N19	68k
R408	NOT PLACED	
R409	0662057M98	10k
R410	0662057N23	100k
R411	0662057M98	10k

Circuit Ref	Motorola Part No.	Description
R413	0662057M01	0
R414	0662057V34	180k
R415	0662057V26	91k
R416	0662057M98	10k
R418	0662057M01	0
R419	0662057M67	510
R420	0662057B46	10M
R421	0662057M81	2000
R423	0662057N39	470k
R424	0662057N12	36k
R425	0662057N10	30k
R426	0662057N35	330k
R427	0662057M84	2700
R428	0662057M10	2.2
R429	0662057N20	75k
R431	0662057N39	470k
R432	0662057N16	51k
R434	0662057M62	330
R435	0662057M81	2000
R436	0662057M01	0
R437	NOT PLACED	
R445	0662057N08	24k
R447	0662057N23	100k
R448	0662057M98	10k
R449	0662057N08	24k
R450	0683962T45	68 ohms, 1W
R451	0662057N03	15k
R452	0662057N23	100k
R453	NOT PLACED	
R454	NOT PLACED	
R455	NOT PLACED	
R456	0662057M01	0
R457	0662057M98	10k
R460	0662057M90	4700
R461	0662057M56	180
R462	0662057M98	10k
R463	0662057M61	300
R471	0662057N06	20k
R472	0662057N12	36k
R473	0662057M26	10
R475	0662057M01	0
R476	0662057N35	330k
R477	0662057M74	1000
R478	0662057M98	10k
R481	0662057N08	24k
R492	0662057M01	0
R498	0662057M98	10k
R499	0662057M98	10k
R501	0662057M70	680
R502	0662057M56	180
R505	0662057M98	10k

Circuit Ref	Motorola Part No.	Description
R506	0662057N15	47k
R507	0662057M01	0
RT400	0680590Z01	THERMISTOR_33K
S501	4080710Z09	Switch
S502	1880619Z02	Volume/on-off switch
SH100	2680507Z01	Harmonic Filter shield
SH101	2680510Z01	RF PA shield
SH201	2680511Z01	Synthesizer top shield
SH202	2680511Z01	Synthesizer bottom shield
SH241	2680513Z01	Resonators shield
SH242	2680514Z01	VCO Buffer IC shield
SH301	2686583Z01	Receiver front-end shield
SH302	2680555Z01	Receiver front-end bottom shield
SH303	2680509Z01	Mixer shield
SH304	2680624Z01	Mixer diode shield
SH322	2686528Z01	IF section shield
SH323	2686527Z01	Crystal Filter shield
SH400	2680505Z01	Controller Memory Shield
SH401	2680506Z01	Controller on-off shield
SH402	2680515Z01	Microprocessor shield
SH403	2680516Z01	Asfic_Cmp/Audio PA shield
T301	2580541Z02	Balun transformer (new)
T302	2580541Z02	Balun transformer (new)
U101	5185130C65	VHF/UHF/800 MHZ LDMOS DRIVER
U102	5185765B26	IC PWR CTRL IN MOS20
U201	5185130C18	IC LV FRAC-N IN 48-PIN TQFP PA
U210	5102463J61	Inverter
U211	5102463J61	Inverter
U241	5105750U54	VCO BUFFER IC
U247	5105739X05	SOT 5V Regulator
U248	5102463J58	3.3V Regulator
U301	5186144B01	FM IFIC SA616
U302	5109522E10	LMOS Inverter
U303	NOT PLACED	
U400	5102463J40	3.3V Regulator
U404	5185130C53	IC ASFIC_CMP_R1
U405	NOT PLACED	
U406	*5102463J59	Flash ROM 128K x 8
U407	*5102463J64	16K x 8 EEPROM
U409	5102226J56	Microprocessor
U410	5102463J57	3.3V Regulator
U420	5102463J44	Audio PA
VR432	4805656W08	5.6V Zener
VR433	4805656W08	5.6V Zener
VR434	4802245J73	ZENER DIODE-6.8V
VR439	4880140L17	ZENER DIODE-12V
VR440	4802245J73	ZENER DIODE-6.8V
VR441	4802245J73	ZENER DIODE-6.8V

Circuit Ref	Motorola Part No.	Description
VR442	4802245J73	ZENER DIODE-6.8V
VR443	4802245J73	ZENER DIODE-6.8V
VR444	4802245J73	ZENER DIODE-6.8V
VR445	4802245J74	ZENER DIODE-10V
VR446	4802245J74	ZENER DIODE-10V
VR447	4802245J74	ZENER DIODE-10V
VR448	4802245J74	ZENER DIODE-10V
VR449	4802245J74	ZENER DIODE-10V
VR450	4802245J75	ZENER DIODE-12V
VR460	4802245J73	ZENER DIODE-6.8V
VR501	4813830A18	6.8V ZENER
VR506	4802245J73	ZENER DIODE-6.8V
Y300	4802245J84	Xtal Oscillator 33.395MHz
Y301	9186145B02	455kHz Ceramic Discriminator
	1485777Z01	INSULATOR (KAPTON)
	8486458Z01	UHF B1 main PC board

* Motorola Depot Servicing only

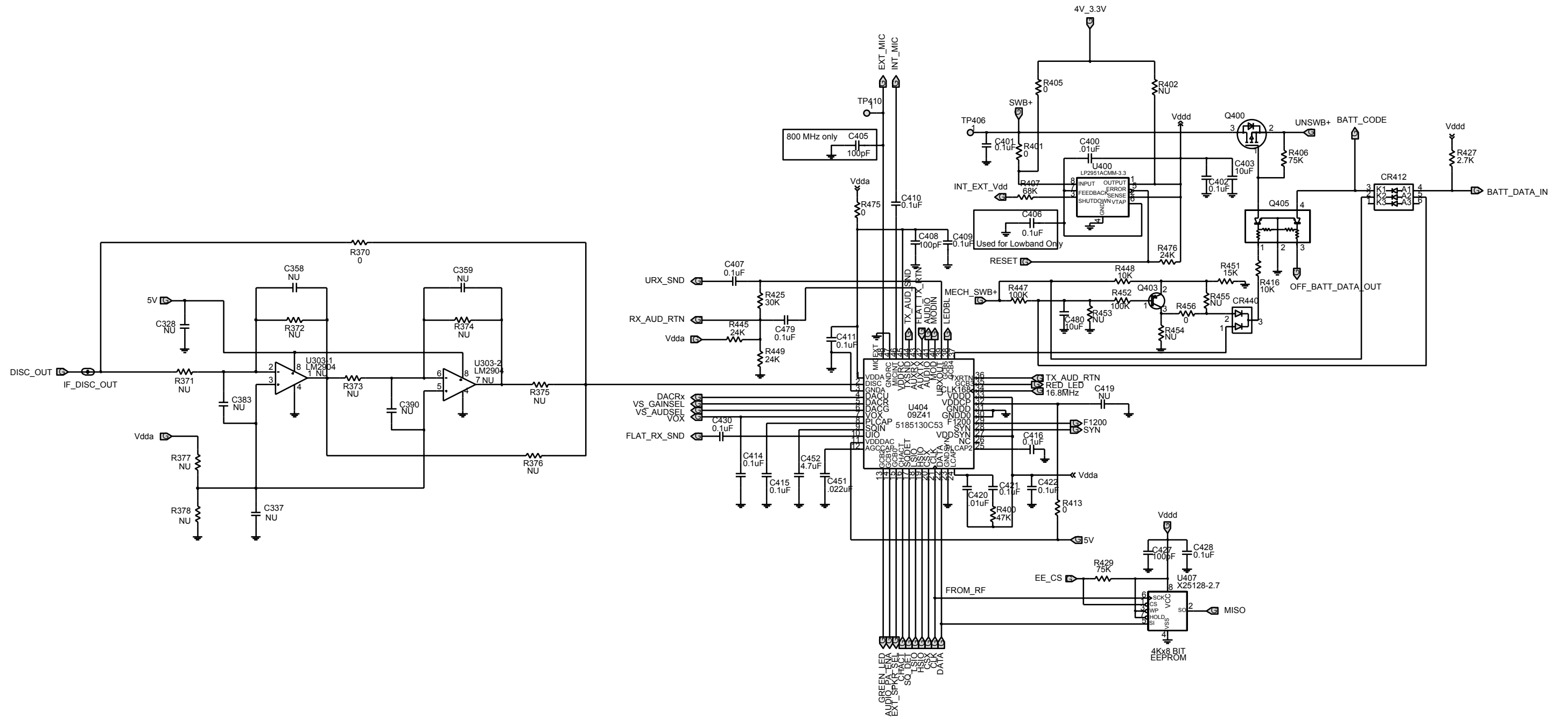
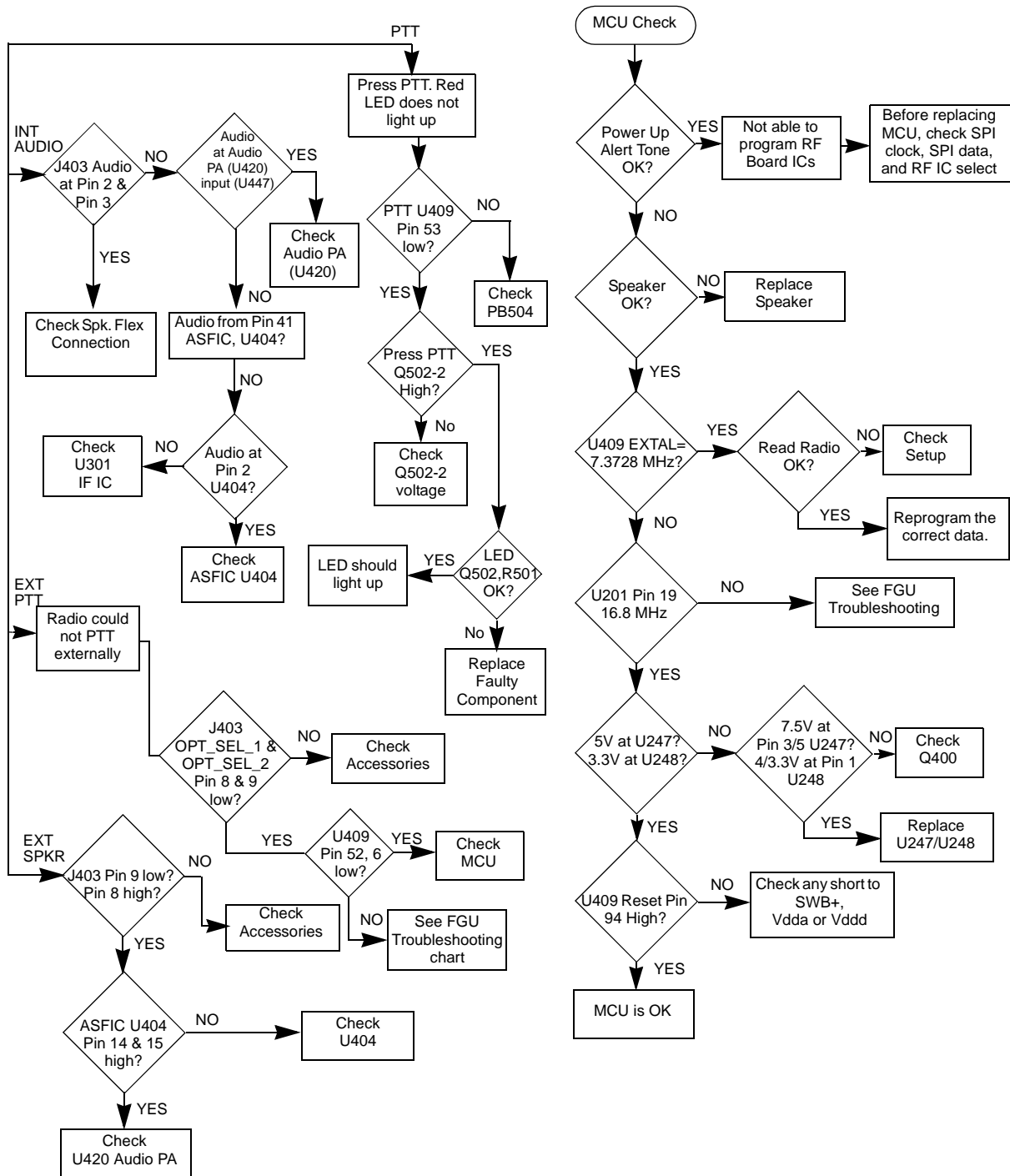

Figure 2-10. Controller ASFIC/ON_OFF Schematic Diagram

Chapter 3 UHF Troubleshooting Charts

3.1 Troubleshooting Flow Chart for Controller



3.2 Troubleshooting Flow Chart for Receiver (Sheet 1 of 2)

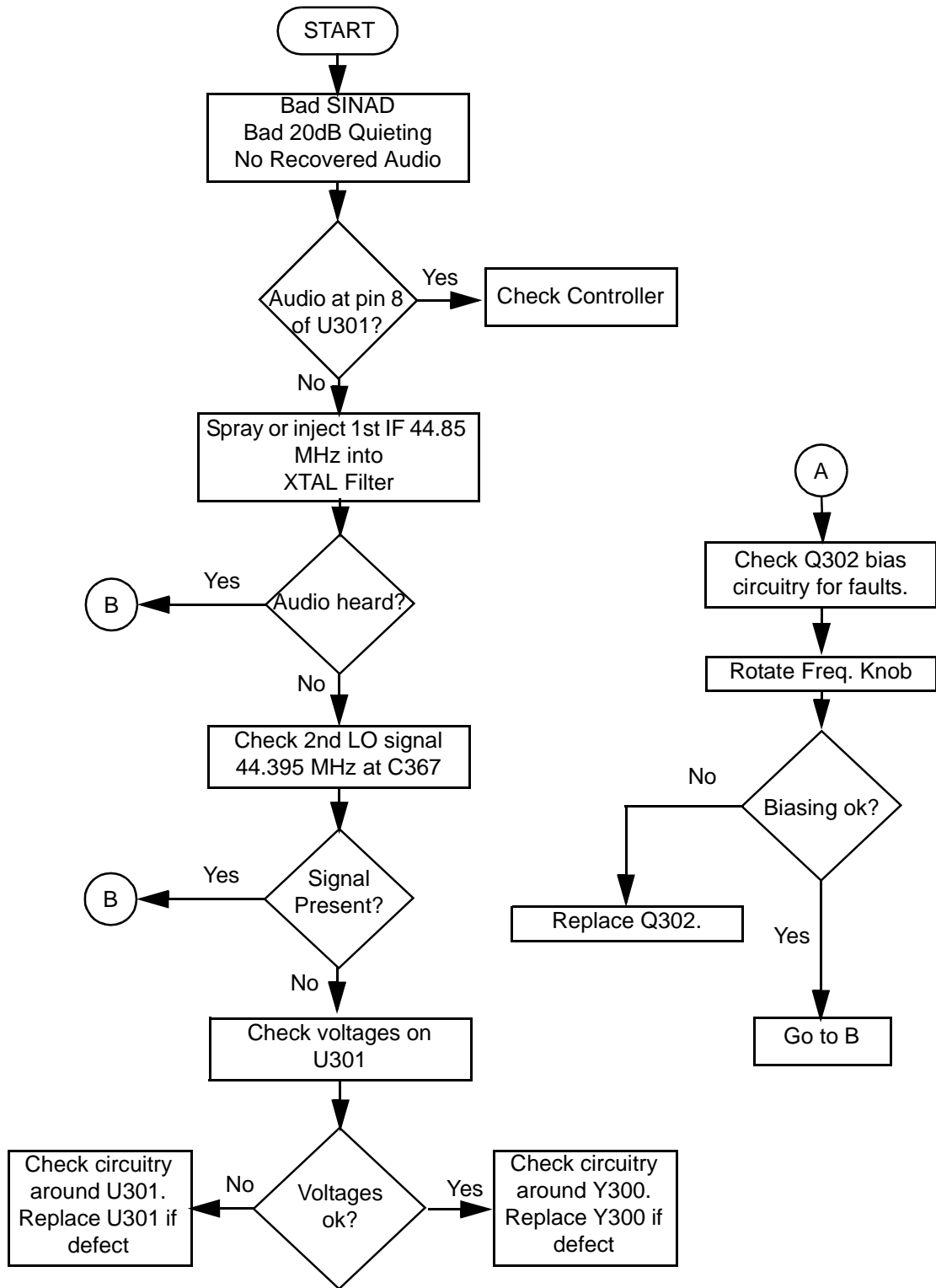

3.3 Troubleshooting Flow Chart for Receiver (Sheet 2 of 2)

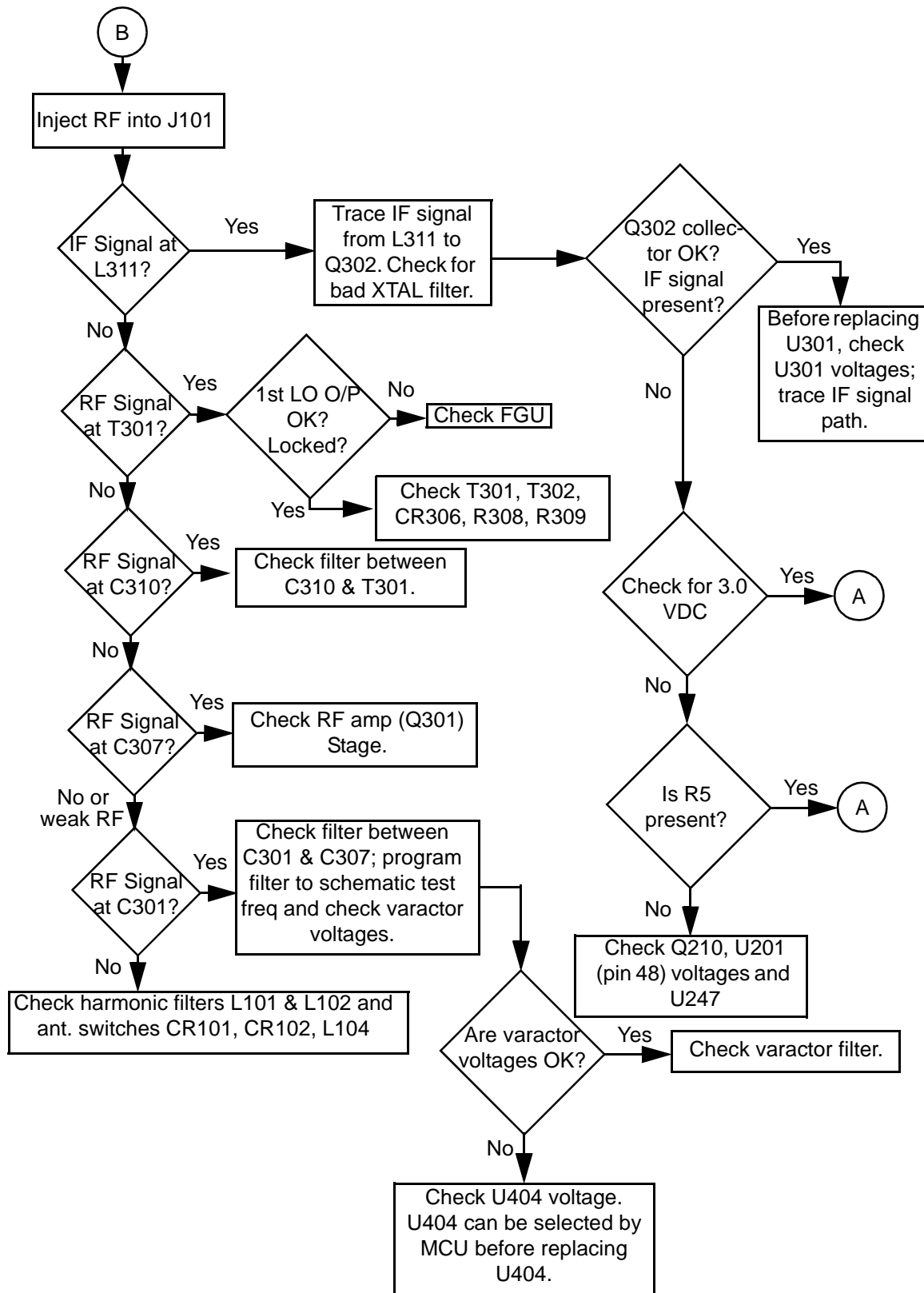

3.4 Troubleshooting Flow Chart for Transmitter

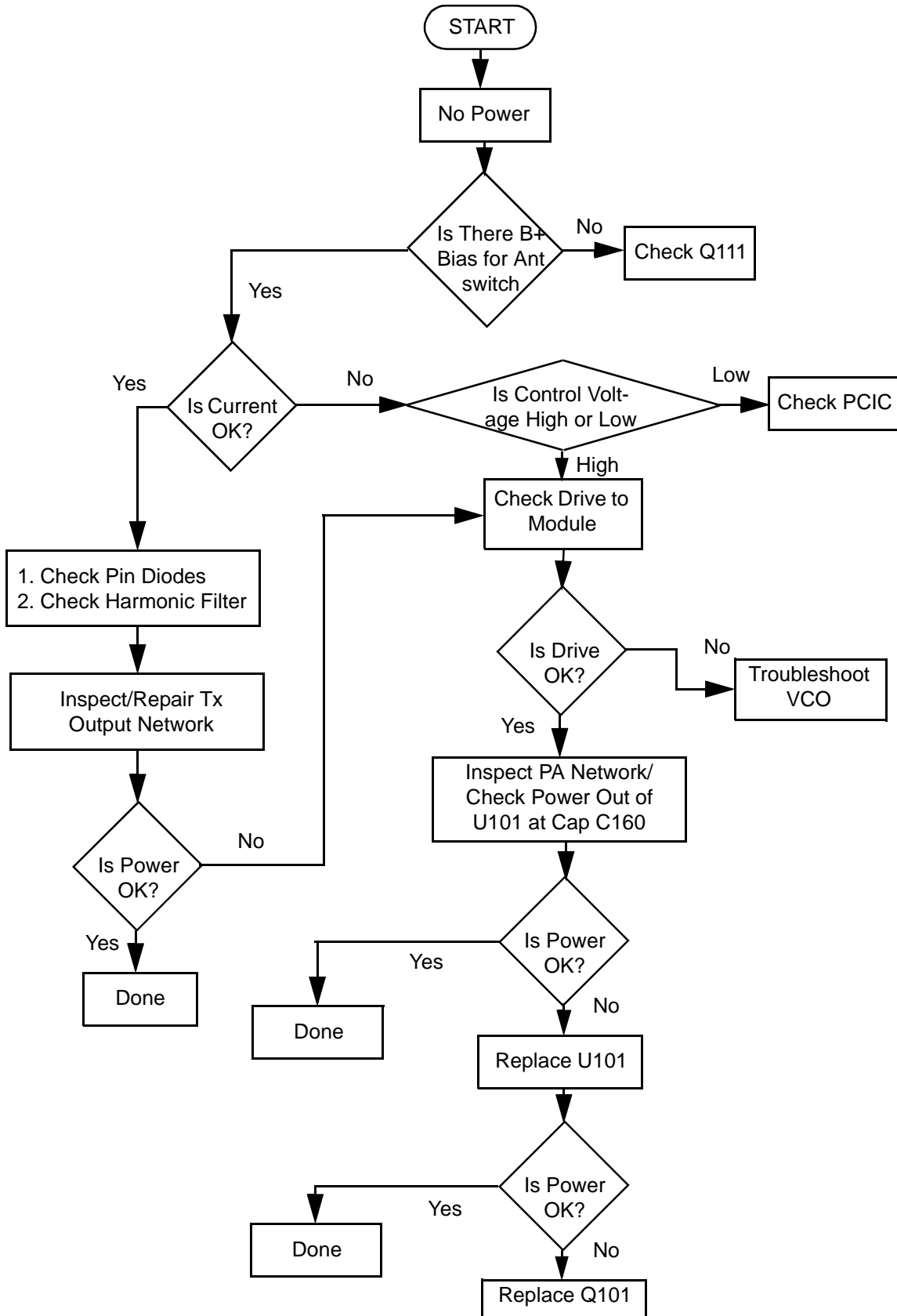

3.5 Troubleshooting Flow Chart for Synthesizer

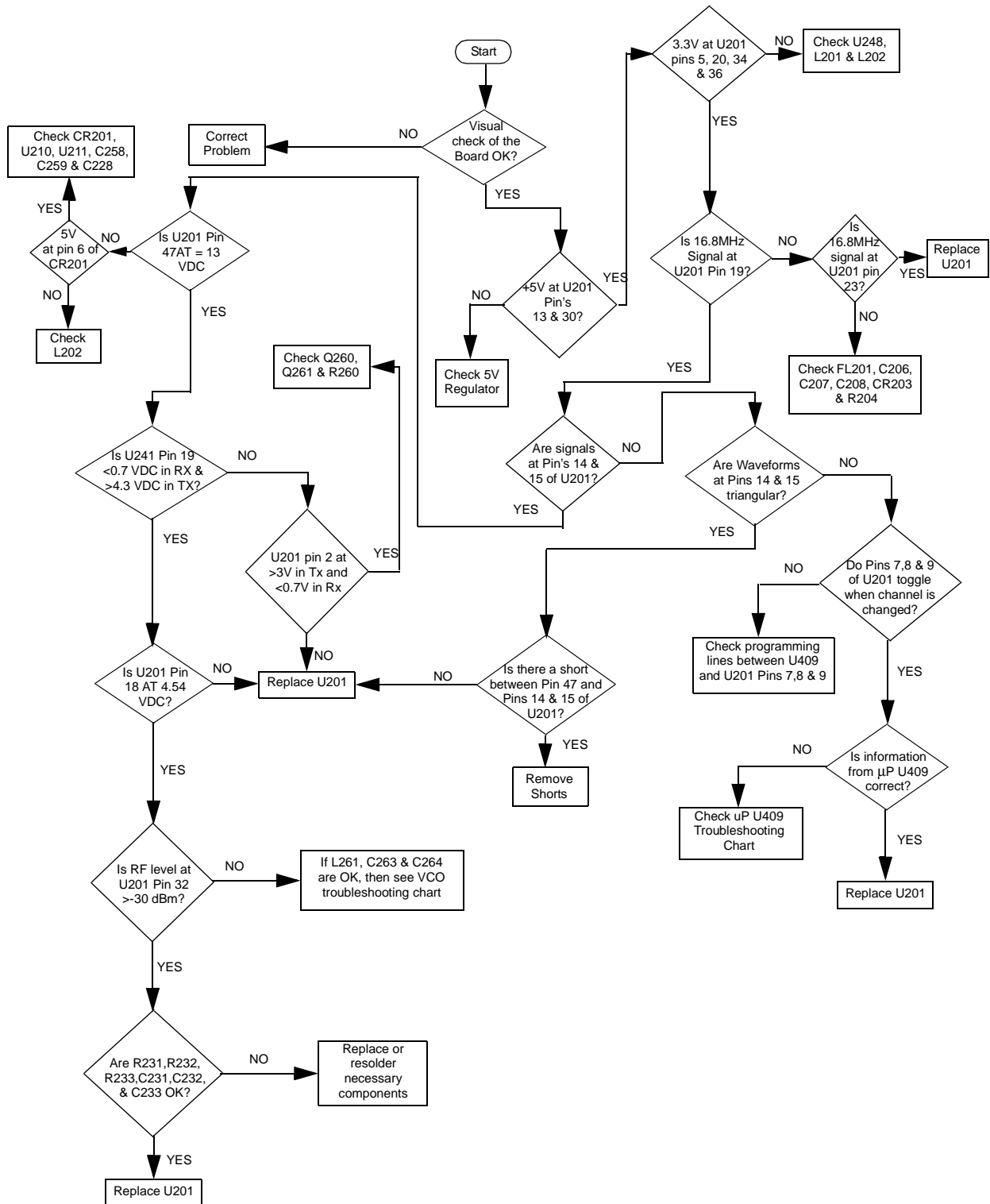

3.6 Troubleshooting Flow Chart for VCO

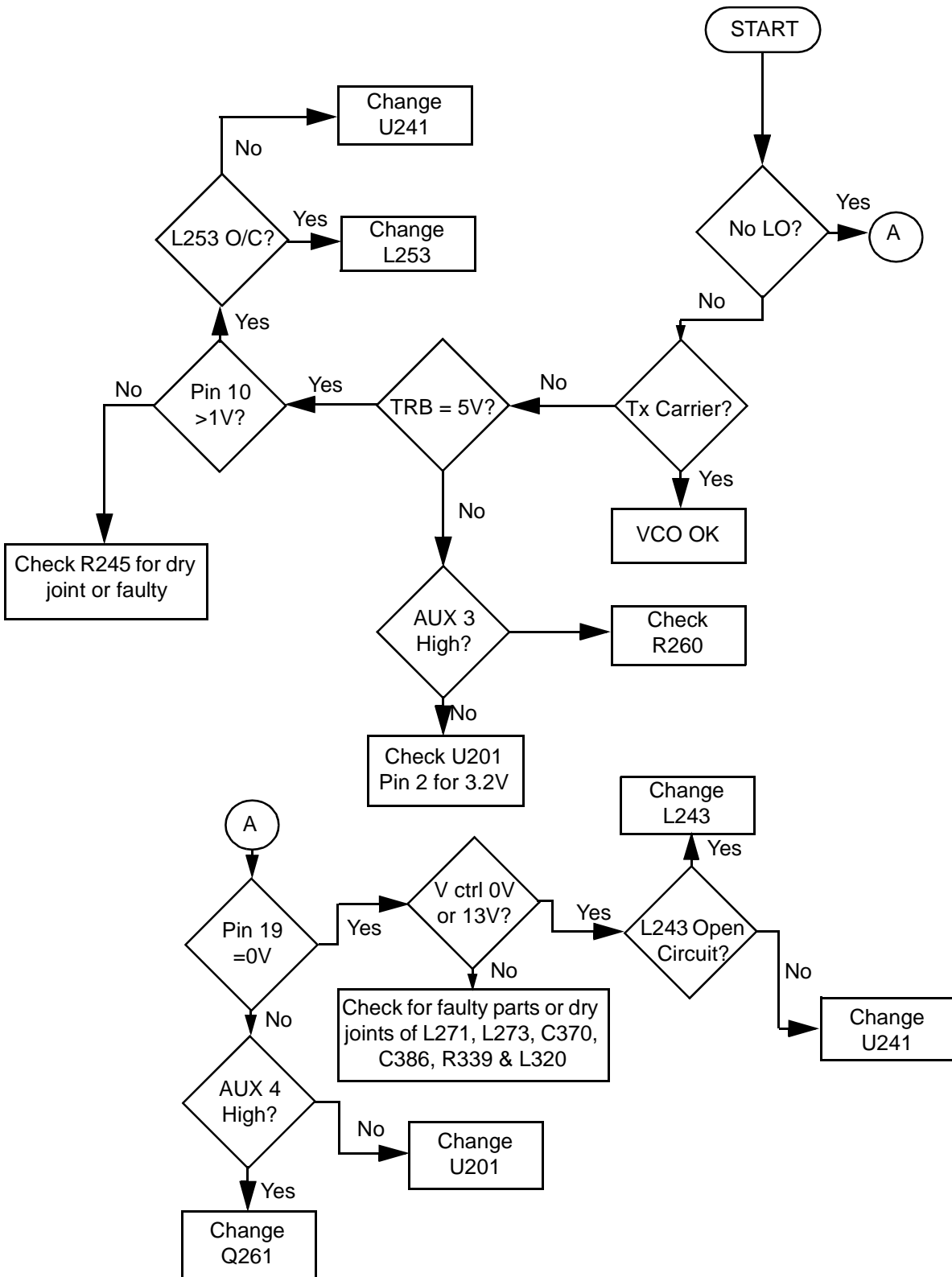

Chapter 4 UHF Band 2 Theory of Operation

4.1 Transmitter

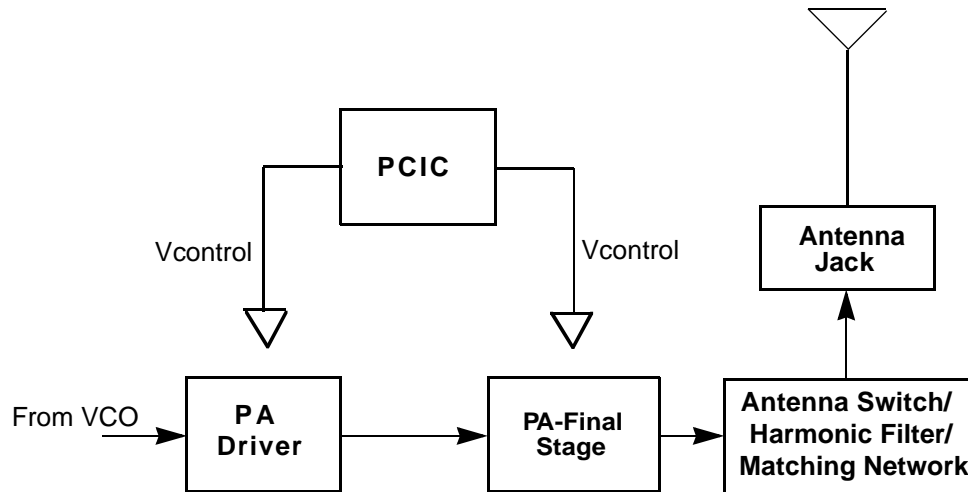

Figure 4-1. Transmitter Block Diagram

4.1.1 General

(Refer to Figure 4-1)

The UHF transmitter contains five basic circuits:

- power amplifier
- antenna switch
- harmonic filter
- antenna matching network
- power control integrated circuit (PCIC)

4.1.2 Power Amplifier

The power amplifier consists of two devices:

- 9Z67 LDMOS driver IC (U101)
- PRF1507 LDMOS PA (Q110)

The 9Z67 LDMOS driver IC contains a 2 stage amplification with a supply voltage of 7.3V.

This RF power amplifier is capable of supplying an output power of 0.3W (pin 6 and 7) with an input signal of 2 mW (3 dBm) (pin16). The current drain would typically be 160 mA while operating in the frequency range of 450-527 MHz.

The PRF1507 LDMOS PA is capable of supplying an output power of 7W with an input signal of 0.3W. The current drain would typically be 1300 mA while operating in the frequency range of 450-527 MHz. The power output can be varied by changing the biasing voltage.

4.1.3 Antenna Switch

The antenna switch circuit consists of two PIN diodes (CR101 and CR102), a pi network (C107, L104 and C106), and two current limiting resistors (R101, R170). In the transmit mode, B+ at PCIC (U102) pin 23 will go low and turn on Q111 where a B+ bias is applied to the antenna switch circuit to bias the diodes "on." The shunt diode (CR102) shorts out the receiver port, and the pi network, which operates as a quarter wave transmission line, transforms the low impedance of the shunt diode to a high impedance at the input of the harmonic filter. In the receive mode, the diodes are both off, and hence, there exists a low attenuation path between the antenna and receiver ports.

4.1.4 Harmonic Filter

The harmonic filter consists of C104, L102, C103, L101 and C102. The design of the harmonic filter for UHF is that of a modified Zolotarev design. It has been optimized for efficiency of the power module. This type of filter has the advantage that it can give a greater attenuation in the stop-band for a given ripple level. The harmonic filter insertion loss is typically less than 1.2 dB.

4.1.5 Antenna Matching Network

A matching network which is made up of L116 is used to match the antenna's impedance to the harmonic filter. This will optimize the performance of the transmitter and receiver into an antenna.

4.1.6 Power Control Integrated Circuit (PCIC)

The transmitter uses the Power Control IC (PCIC), U102 to regulate the power output of the radio. The current to the final stage of the power module is supplied through R101, which provides a voltage proportional to the current drain. This voltage is then fed back to the Automatic Level Control (ALC) within the PCIC to regulate the output power of the transmitter.

The PCIC has internal digital to analog converters (DACs) which provide the reference voltage of the control loop. The reference voltage level is programmable through the SPI line of the PCIC.

There are resistors and integrators within the PCIC, and external capacitors (C133, C134 and C135) in controlling the transmitter rising and falling time. These are necessary in reducing the power splatter into adjacent channels.

CR105 and its associated components are part of the temperature cut back circuitry. It senses the printed circuit board temperature around the transmitter circuits and output a DC voltage to the PCIC. If the DC voltage produced exceeds the set threshold in the PCIC, the transmitter output power will be reduced so as to reduce the transmitter temperature.

The output of the post-RF amplifier filter which is connected to the passive double balanced mixer consists of T301, T302, and CR306. Matching of the filter to the mixer is provided by C381. After mixing with the first LO signal from the voltage controlled oscillator (VCO) using low side injection, the RF signal is down-converted to the 44.85 MHz IF signal.

The IF signal coming out of the mixer is transferred to the crystal filter (FL301) through a resistor pad and a diplexer (C322 and L310). Matching to the input of the crystal filter is provided by C324 and L311. The crystal filter provides the necessary selectivity and intermodulation protection.

4.2.2 Receiver Back-End

(Refer to “Figure 5-5. UHF Band 2 Receiver Back End Schematic Diagram” on page 51.)

The output of crystal filter FL301 is matched to the input of first IF amplifier transistor Q302 by L330. Voltage supply to the IF amplifier is taken from the receive 5 volts (R5). The IF amplifier provides a gain of about 16 dB. The amplified first IF signal is then coupled into U301 (pin 1) via C360 and L332, which provides the matching for the first IF amplifier and U301.

Within U301, the first IF 44.85 MHz signal mixes with the 44.395 MHz second local oscillator (2nd LO) to produce the second IF signal at 455 kHz. The 2nd LO signal frequency is determined by crystal Y300. The second IF signal (455 kHz) is then filtered by an external ceramic filter FL302 before being amplified by the second IF amplifier within U301. Again, the signal is filtered by a second external ceramic filter FL303 or FL304, depending on the selected channel spacing. FL303 is used for 20/25 kHz channel spacing whereas FL304 is used for 12.5 kHz channel spacing. The simple circuit consisting of U302, CR312, CR313 and resistors R345, R360, R321, and R324 divert the second IF signal according to the BW_SEL line. The filtered output of the second IF signal is applied to the limiter input pin of U301.

The IF IC (U301) contains a quadrature detector using a ceramic phase-shift element (Y301) to provide audio detection. Internal amplification provides an audio output level around 120 mVrms (@60% deviation) from pin 8 of U301. This demodulated audio is fed to the ASFIC_CMP IC (U404) in the controller section.

The IF IC (U301) also performs several other functions. It provides a received signal-strength indicator (RSSI) with a dynamic range of 70 dB. The RSSI is a DC voltage monitored by the microprocessor, and is used as a peak indicator during the bench tuning of the receiver front-end varactor filter.

4.3 Frequency Generation Circuitry

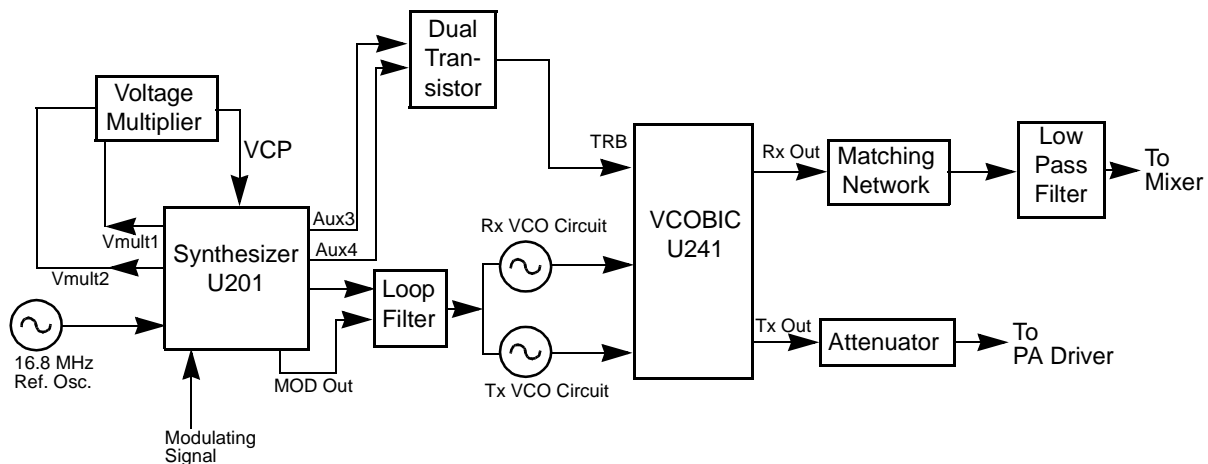

Figure 4-3. Frequency Generation Unit Block Diagram

The Frequency Generation Circuitry is composed of two main ICs:

- Fractional-N synthesizer (U201)
- VCO/Buffer IC (U241)

Designed in conjunction to maximize compatibility, the two ICs provide many of the functions that normally would require additional circuitry. The synthesizer block diagram illustrates the interconnect and support circuitry used in the region. Refer to the relevant schematics for the reference designators.

The synthesizer is powered by regulated 5V and 3.3V, which come from U247 and U248, respectively. The synthesizer in turn generates a superfiltered 4.5V which powers U241.

In addition to the VCO, the synthesizer must interface with the logic and ASFIC circuitry. Programming for the synthesizer is accomplished through the data, clock and chip select lines from the microprocessor. A 3.3V DC signal from synthesizer lock detect line indicates to the microprocessor that the synthesizer is locked.

Transmit modulation from the ASFIC is supplied to pin 10 of U201. Internally, the audio is digitized by the Fractional-N and applied to the loop divider to provide the low-port modulation. The audio runs through an internal attenuator for modulation balancing purposes before going out to the VCO.

4.4 Synthesizer

(Refer to "Figure 5-6. UHF Band 2 Synthesizer Schematic Diagram" on page 52.)

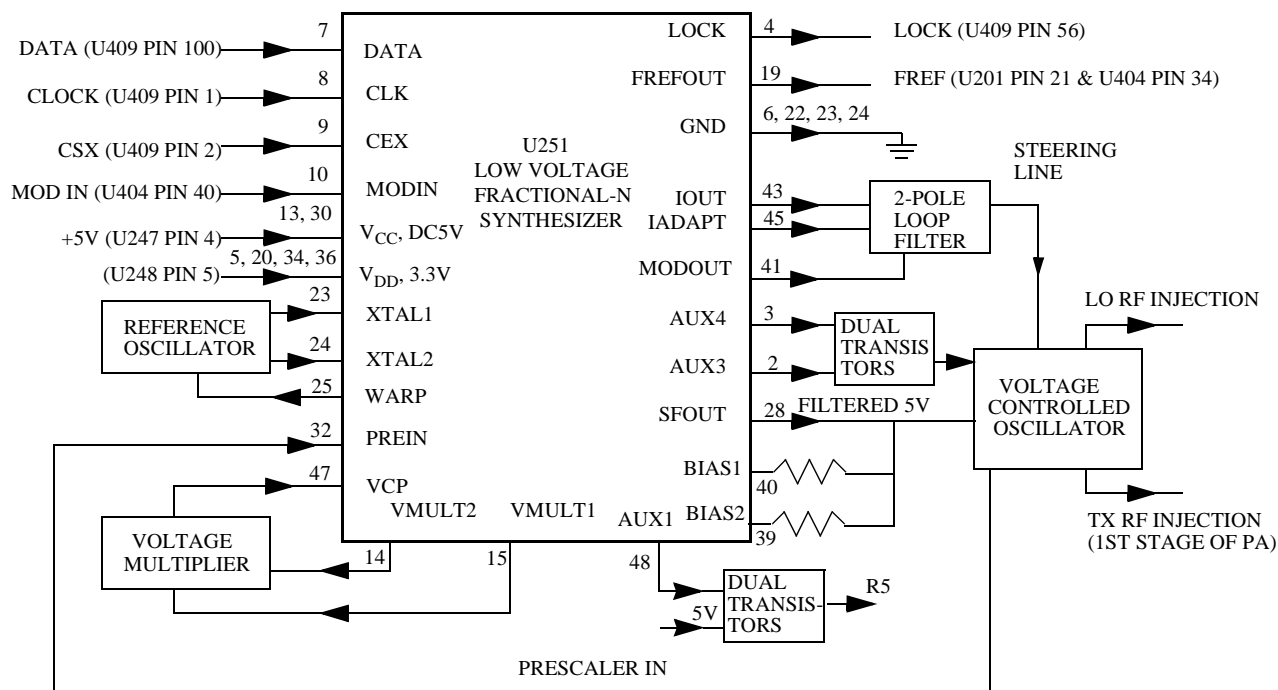

Figure 4-4. Synthesizer Block Diagram

The Fractional-N Synthesizer uses a 16.8 MHz crystal (FL201) to provide a reference for the system. The LVFractN IC (U201) further divides this to 2.1 MHz, 2.225 MHz, and 2.4 MHz as reference frequencies. Together with C206, C207, C208, R204, and CR203, they build up the reference oscillator which is capable of 2.5 ppm stability over temperatures of -30 to 85°C . It also provides 16.8 MHz at pin 19 of U201 to be used by ASFIC.

The loop filter, which consists of C231, C232, C233, R231, R232, and R233, provides the necessary DC steering voltage for the VCO and determines the amount of noise and spur passing through.

In achieving fast locking for the synthesizer, an internal adapt charge pump provides higher current at pin 45 of U201 to put the synthesizer within the lock range. The required frequency is then locked by normal mode charge pump at pin 43.

Both the normal and adapt charge pumps get their supply from the capacitive voltage multiplier, which is made up of C258, C259, C228, triple diode CR201 and level shifters U210 and U211. Two 3.3V square waves (180 deg out of phase) are first shifted to 5V, then along with regulated 5V, put through arrays of diodes and capacitors to build up 13.3V at pin 47 of U201.

4.5 Voltage-Controlled Oscillator (VCO)

(Refer to "Figure 5-7. UHF Band 2 Voltage Controlled Oscillator Schematic Diagram" on page 53.

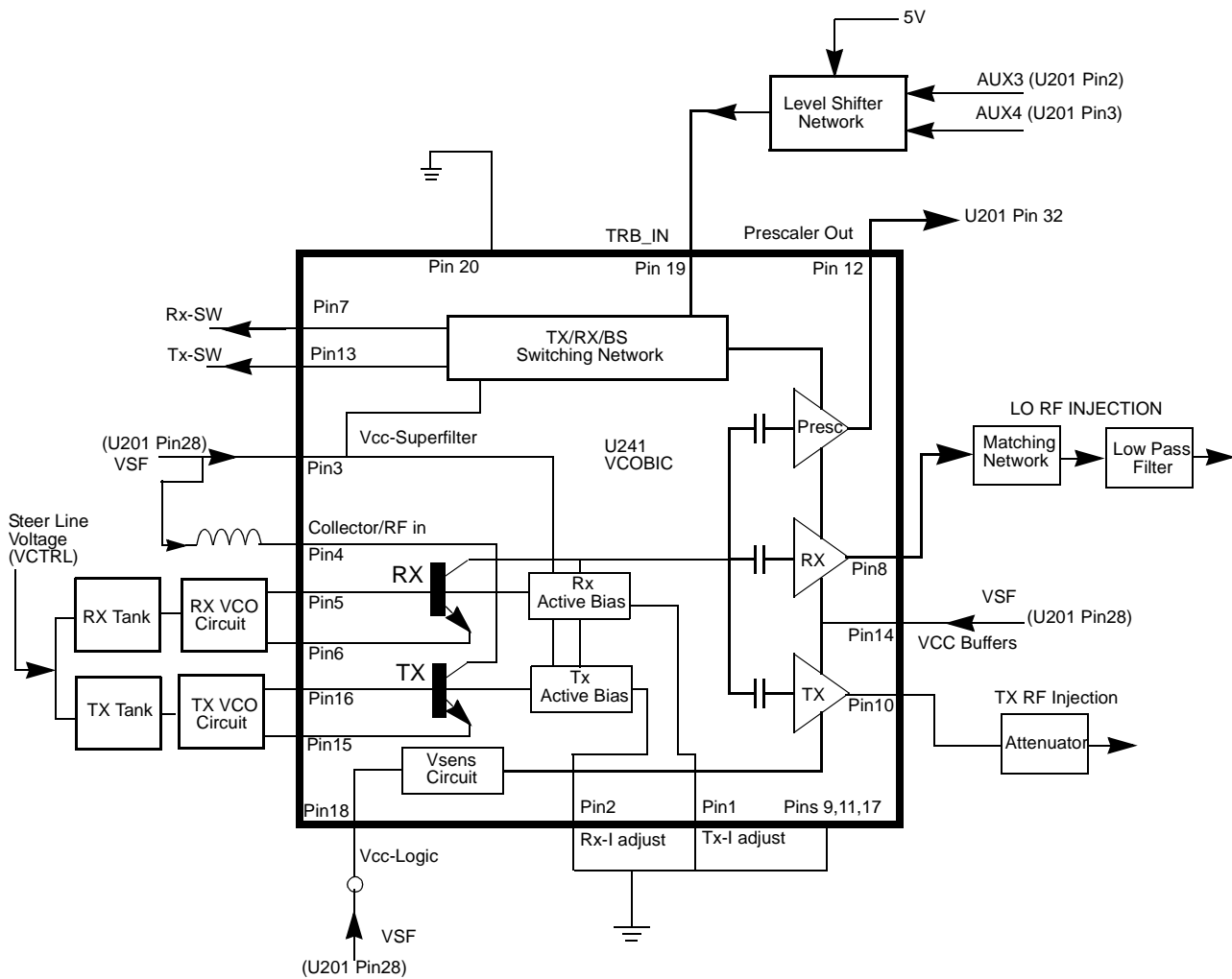

Figure 4-5. VCO Block Diagram

The VCOBIC (U241), in conjunction with the Fractional-N synthesizer (U201), generates RF in both the receive and the transmit modes of operation. The TRB line (U241 pin 19) determines which oscillator and buffer will be enabled. A sample of the RF signal from the enabled oscillator is routed from U241 pin 12, through a low pass filter, to the prescaler input (U201 pin 32). After frequency comparison in the synthesizer, a resultant CONTROL VOLTAGE is received at the VCO. This voltage is a DC voltage between 3.5V and 9.5V when the PLL is locked on frequency.

The VCOBIC (U241) is operated at 4.54V (VSF) and Fractional-N synthesizer (U201) at 3.3V. This difference in operating voltage requires a level shifter consisting of Q260 and Q261 on the TRB line.

The operation logic is shown in Table 4-1.

Table 4-1. Level Shifter Logic

Desired Mode	AUX 4	AUX 3	TRB
Tx	Low	High (@3.2V)	High (@4.8V)
Rx	High	Low	Low
Battery Saver	Low	Low	Hi-Z/Float (@2.5V)

In the receive mode, U241 pin 19 is low or grounded. This activates the receive VCO by enabling the receive oscillator and the receive buffer of U241. The RF signal at U241 pin 8 is run through a matching network. The resulting RF signal is the LO RF INJECTION, and it is applied to the mixer at T302 (refer to "Figure 5-4. UHF Band 2 Receiver Front End Schematic Diagram" on page 50).

During the transmit condition, when PTT is depressed, five volts is applied to U241 pin 19. This activates the transmit VCO by enabling the transmit oscillator and the transmit buffer of U241. The RF signal at U241 pin 10 is injected into the input of the PA module (U101 pin16). This RF signal is the TX RF INJECTION. Also in transmit mode, the audio signal to be frequency modulated onto the carrier is received through the U201 pin 41.

When a high impedance is applied to U241 pin 19, the VCO is operating in BATTERY SAVER mode. In this case, both the receive and transmit oscillators as well as the receive transmit and prescaler buffer are turned off.

This page intentionally left blank.

Chapter 5 UHF Band 2 CB Layouts, Schematic Diagrams, and Parts List

5.1 Notes For All Schematics and Circuit Boards

* Component is frequency sensitive. Refer to the Electrical Parts List for value and usage.

1. Unless otherwise stated, resistances are in Ohms ($k = 1000$), and capacitances are in picofarads (pF) or microfarads (μF).
2. DC voltages are measured from point indicated to chassis ground using a Motorola DC multimeter or equivalent. Transmitter measurements should be made with a $1.2 \mu H$ choke in series with the voltage probe to prevent circuit loading.
3. Reference Designators are assigned in the following manner:

100 Series = Transmitter
200 Series = Frequency Generation
300 Series = Receiver
400/500 Series = Controller
600 Series = Keypad Board

4. Interconnect Tie Point Legend:

UNSWB+ = Unswitch Battery Voltage (7.5V)
SWB+ = Switch Battery Voltage (7.5V)
R5 = Receiver Five Volts
CLK = Clock
Vdda = Regulated 3.3 Volts (for analog)
Vddd = Regulated 3.3 Volts (for digital)
CSX = Chip Select Line
SYN = Synthesizer
DACRX = Digital to Analog Voltage (For Receiver Front End Filter)
VSF = Voltage Super Filtered (5 volts)
VR = Voltage Regulator

6-LAYER CIRCUIT BOARD DETAIL VIEWING COPPER STEPS IN PROPER LAYER SEQUENCE

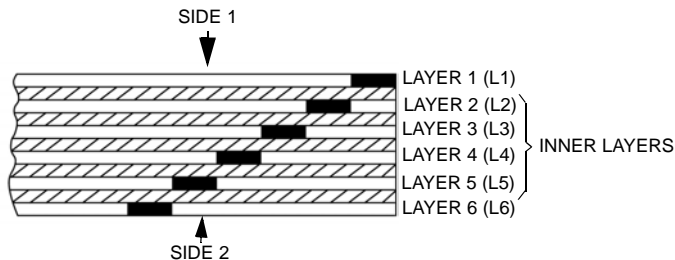

This page intentionally left blank.

5.2 Circuit Board/Schematic Diagrams and Parts List

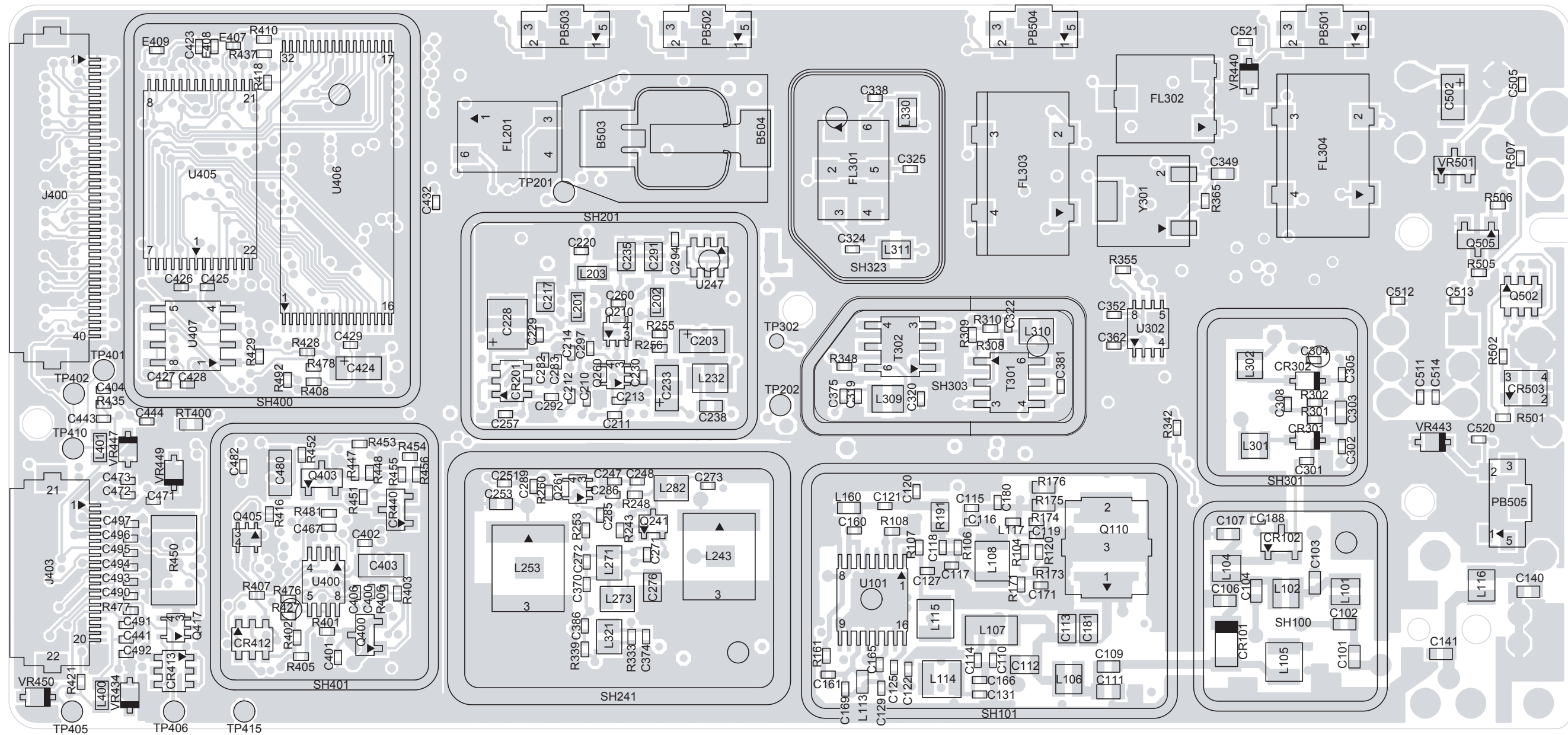

Figure 5-1. UHF Band 2 (450-527 MHz) Main Board Top Side PCB No. 8486686Z01

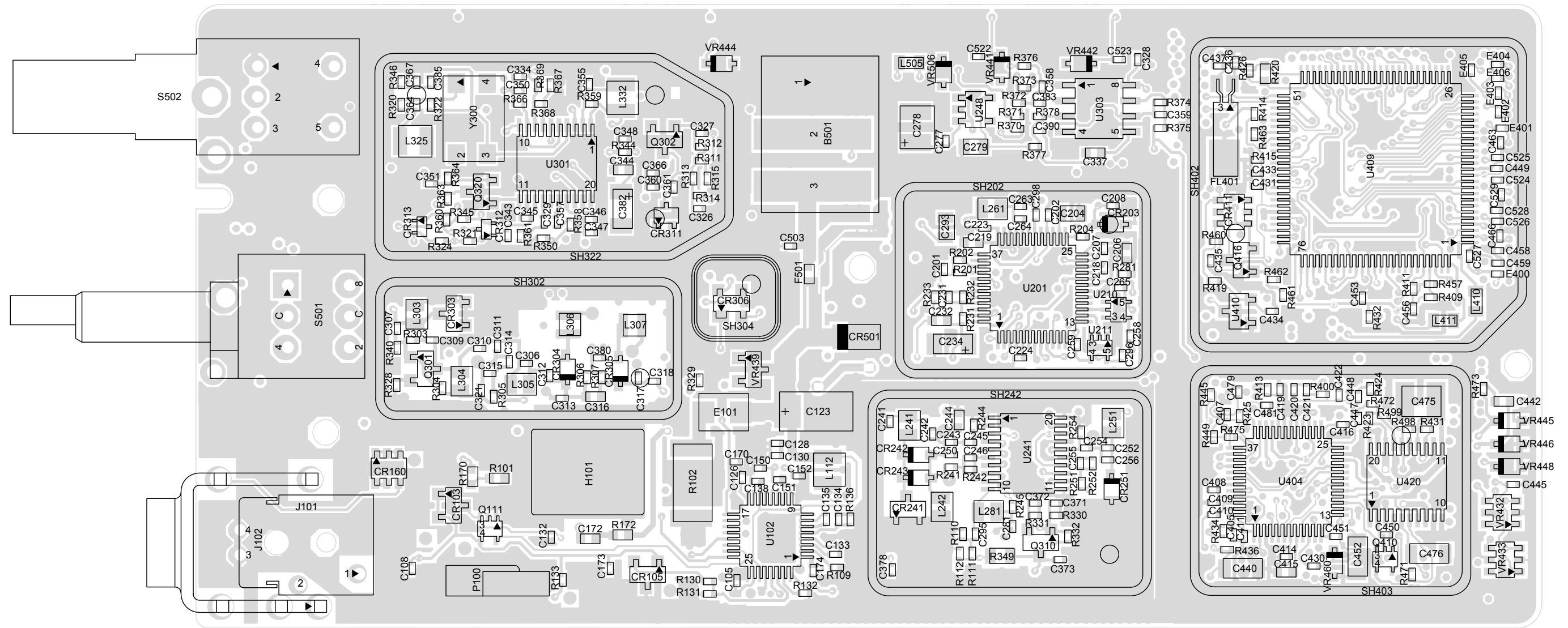

Figure 5-2. UHF Band 2 (450-527 MHz) Main Board Bottom Side PCB No. 8486686Z01

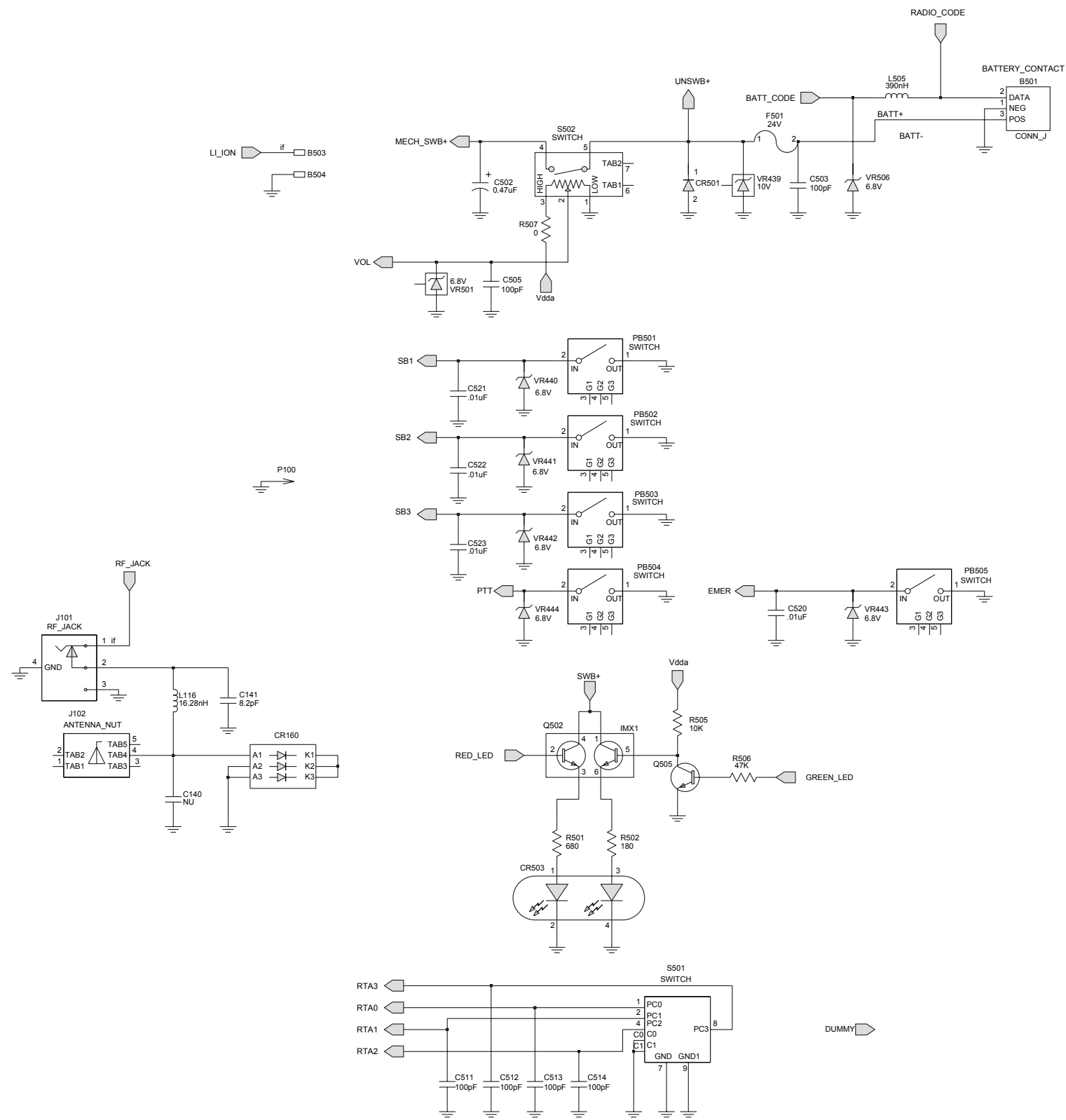

Figure 5-3. UHF Band 2 Controls and Switches Schematic Diagram

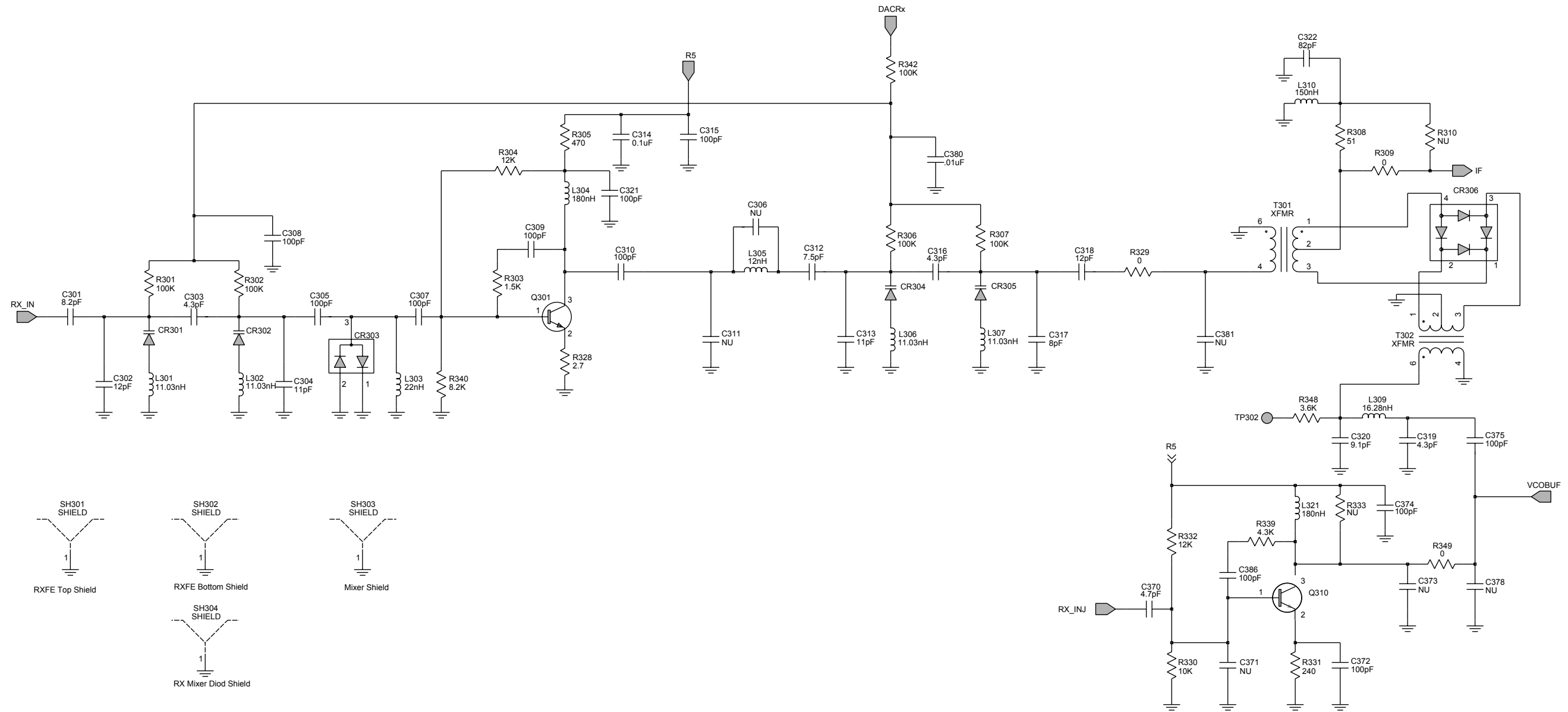

Figure 5-4. UHF Band 2 Receiver Front End Schematic Diagram

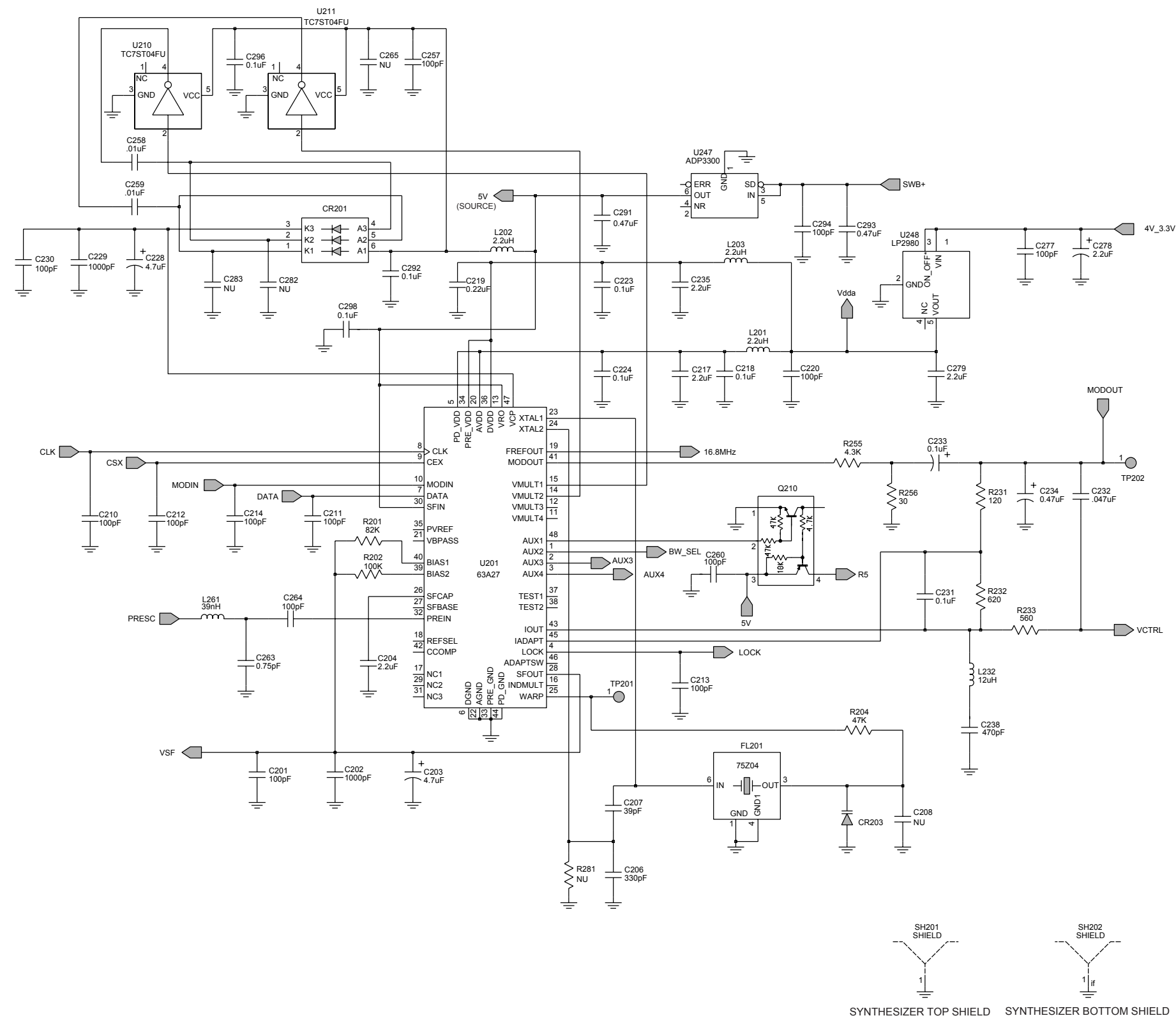

Figure 5-6. UHF Band 2 Synthesizer Schematic Diagram

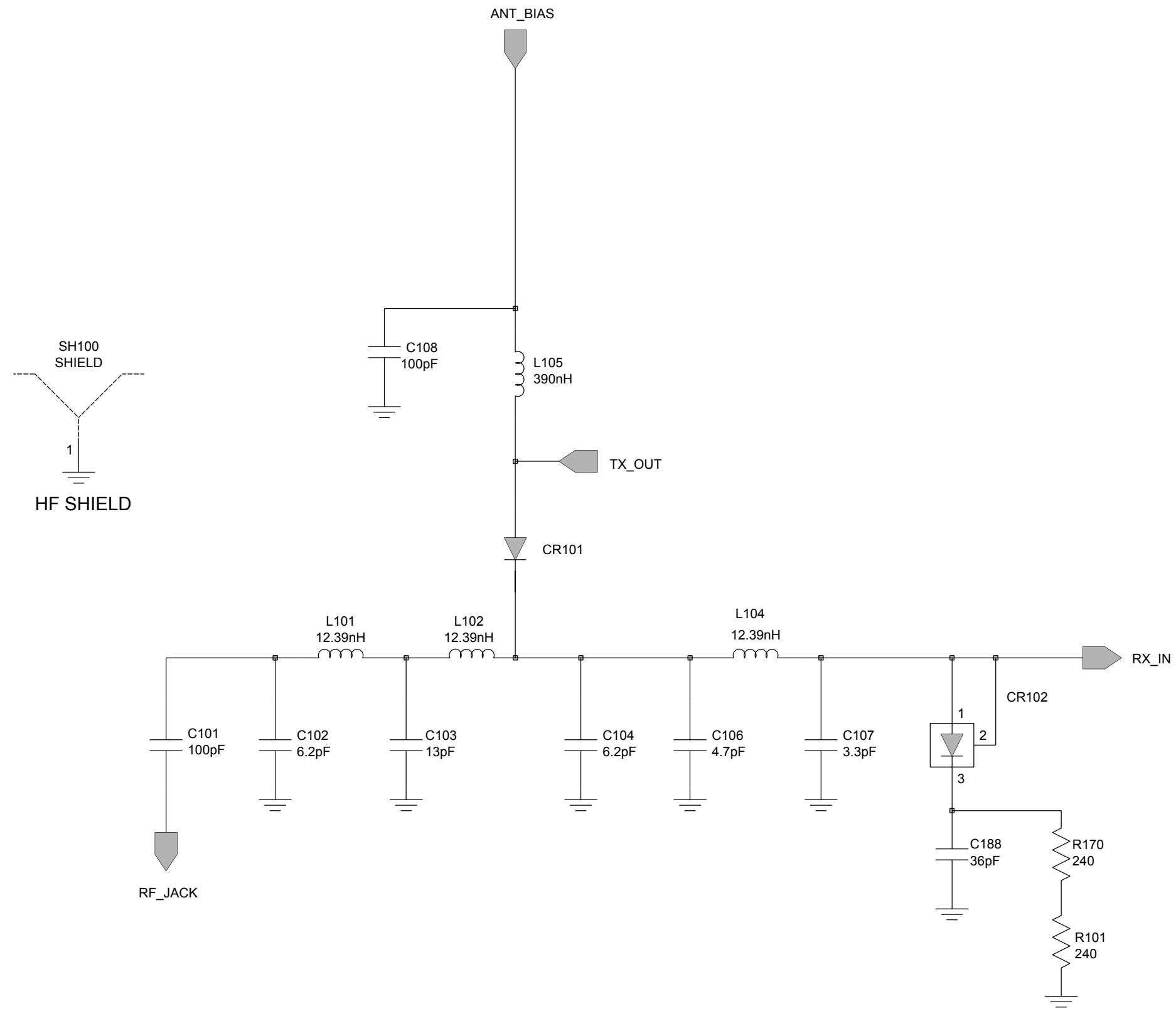

Figure 5-8. UHF Band 2 Harmonic Filter Schematic Diagram

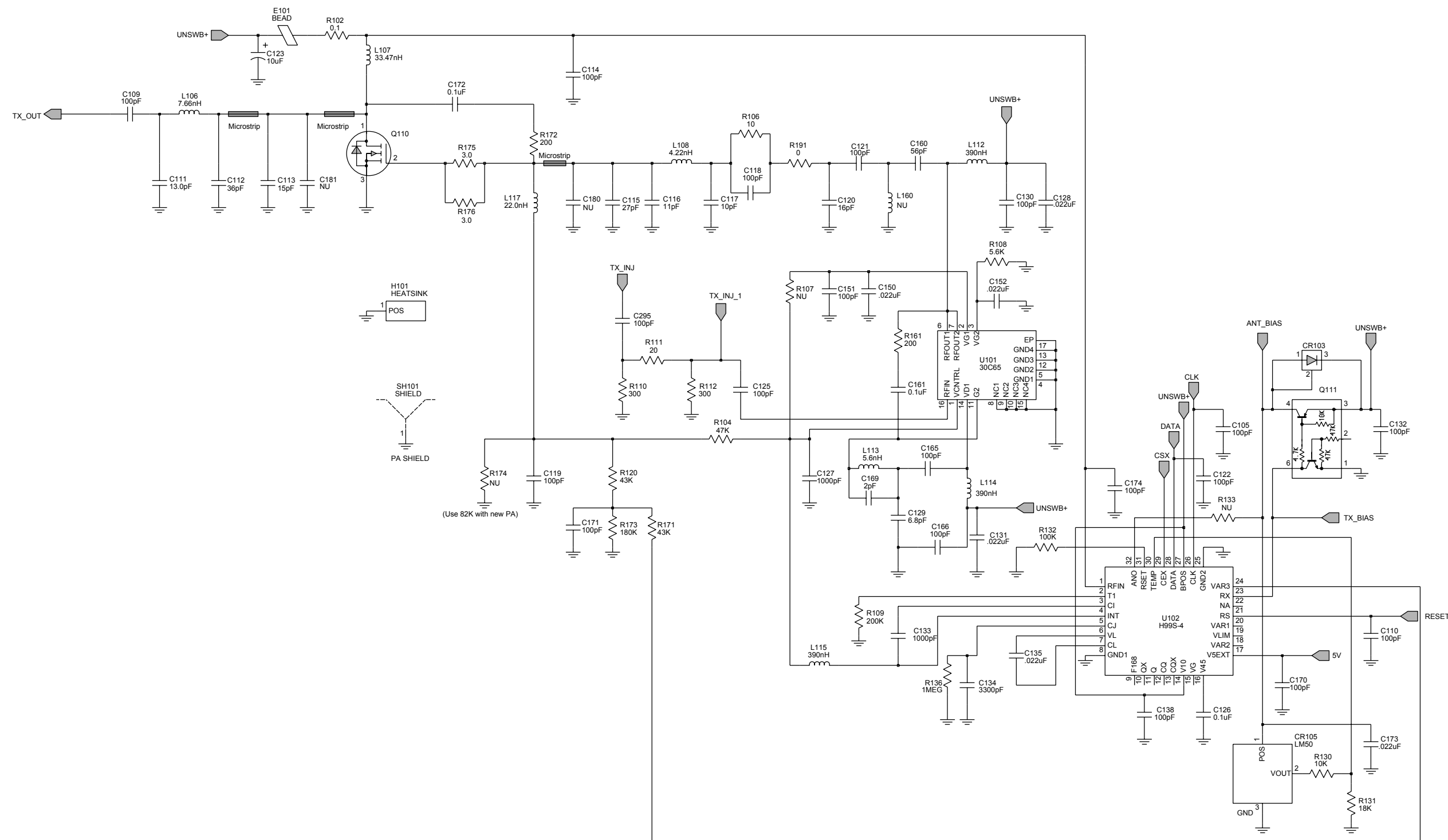

Figure 5-9. UHF Band 2 Transmitter Schematic Diagram

UHF Band 2 Radio Parts List

Circuit Ref	Motorola Part No.	Description
B501	0986237A02	Battery Contact Module
B503	3980502Z01	Backup battery B+ (Not placed in GP328)
B504	3980501Z01	Backup battery B- (Not placed in GP328)
C101	2113740F51	100pF
C102	2113740F22	6.2pF
C103	2113740F28	11pF
C104	2113740F22	6.2pF
C105	2113743N50	100pF
C106	2113740F19	4.7pF
C107	2113740F15	3.3pF
C108	2113743N50	100pF
C109	2113740F51	100pF
C110	2113743N50	100pF
C111	2103689A22	11pF
C112	2180605Z28	33pF
C113	2180605Z20	15pF
C114	2113743N50	100pF
C115	2113743N31	16pF
C116	2113743N27	11pF
C117	NOT PLACED	
C118	2113743N50	100pF
C119	2113743N50	100pF
C120	2113743N23	7.5pF
C121	2113743N50	100pF
C122	2113743N50	100pF
C123	2311049A96	33uF
C125	2113743N50	100pF
C126	2113743M24	0.1uF
C127	2113743L17	1000pF
C128	2113743M08	0.022uF
C129	2113743N23	7.5pF
C130	2113743N50	100pF
C131	2113743M08	0.022uF
C132	2113743N50	100pF
C133	2113743L17	1000pF
C134	2113743L29	3300pF
C135	2113743M08	0.022uF
C138	2113743N50	100pF
C140	0662057A67	5.6K
C141	2113740F25	8.2pF
C150	2113743M08	0.022uF
C151	2113743N50	100pF
C152	2113743M08	0.022uF
C160	2113743N44	56pF
C161	2113743M24	0.1uF
C165	2113743N44	56pF
C166	2113743N50	100pF

Circuit Ref	Motorola Part No.	Description
C169	2113743N09	2pF
C170	2113743N50	100pF
C171	2113743N50	100pF
C172	2113743E20	0.1uF
C173	2113743M08	0.022uF
C174	2113743N50	100pF
C180	NOT PLACED	
C181	NOT PLACED	
C188	2113743N39	36pF
C201	2113743N50	100pF
C202	2113743L17	1000pF
C203	2311049A56	4.7uF
C204	2104993J02	2.2uF
C206	2113740F63	330pF
C207	2113743N40	39pF
C208	NOT PLACED	
C210	2113743N50	100pF
C211	2113743N50	100pF
C212	2113743N50	100pF
C213	2113743N50	100pF
C214	2113743N50	100pF
C217	2104993J02	2.2uF
C218	2113743M24	0.1uF
C219	2113743K16	0.22uF
C220	2113743N50	100pF
C223	2113743M24	0.1uF
C224	2113743M24	0.1uF
C228	2311049J11	4.7uF
C229	2113743L17	1000pF
C230	2113743N50	100pF
C231	2113743M24	0.1uF
C232	2113743E12	0.047uF
C233	2311049A01	0.1uF
C234	2311049A05	0.47uF
C235	2104993J02	2.2uF
C238	2113741F17	470pF
C241	2113743N50	100pF
C242	2113743N17	4.3pF
C243	2113743N17	4.3pF
C244	2113740F14	3pF
C245	2113743N12	2.7pF
C246	2113743N50	100pF
C247	2113743N50	100pF
C248	2113743M24	0.1uF
C250	2113743N17	4.3pF
C251	2113743N50	100pF
C252	2113743N19	5.1pF
C253	2113740F09	1.8pF
C254	2113743N26	10pF
C255	2113743N50	100pF
C256	2113743N19	5.1pF

Circuit Ref	Motorola Part No.	Description
C257	2113743N50	100pF
C258	2113743L41	0.01uF
C259	2113743L41	0.01uF
C260	2113743N50	100pF
C263	2113743N02	0.75pF
C264	2113743N50	100pF
C265	NOT PLACED	
C271	NOT PLACED	
C272	2109445U01	0.5pF 1%
C273	2113743M24	0.1uF
C276	2104993J02	2.2uF
C277	2113743N50	100pF
C278	2311049A57	10uF
C279	2104993J02	2.2uF
C281	2113743N50	100pF
C282	NOT PLACED	
C283	NOT PLACED	
C285	2113743N50	100pF
C286	2113743M24	0.1uF
C289	2113743N50	100pF
C291	2311049A69	10uF
C292	2113743M24	0.1uF
C293	2113743A27	0.47uF
C294	2113743N50	100pF
C295	2113743N50	100pF
C296	2113743M24	0.1uF
C297	2113743L41	0.01uF
C298	2113743M24	0.1uF
C301	2113743N24	8.2pF
C302	2113743N28	12pF
C303	2113740L09	4.3pF
C304	2113743N27	11pF
C305	2113743N50	100pF
C306	NOT PLACED	
C307	2113743N50	100pF
C308	2113743N50	100pF
C309	2113743N50	100pF
C310	2113743N50	100pF
C311	NOT PLACED	
C312	2113743N23	7.5pF
C313	2113743N27	11pF
C314	2113743M24	0.1uF
C315	2113743N50	100pF
C316	2113740L09	4.3pF
C317	2113743N65	8pF
C318	2113743N28	12pF
C319	2113743N17	4.3pF
C320	2113743N25	9.1pF
C321	2113743N50	100pF
C322	2113743N48	82pF
C324	2109445U40	20pF 1%

Circuit Ref	Motorola Part No.	Description
C325	2109445U26	9.1pF
C326	2113743M24	0.1uF
C327	2113743M24	0.1uF
C328	2113743M24	0.1uF
C329	2113743M24	0.1uF
C334	2113743L33	4700pF
C337	NOT PLACED	
C338	NOT PLACED	
C343	2113743M24	0.1uF
C344	2113743E20	0.1uF
C345	2113743M24	0.1uF
C346	2113743M24	0.1uF
C347	2113743M24	0.1uF
C348	2113743M24	0.1uF
C349	2113743E20	0.1uF
C350	2113743M24	0.1uF
C351	2113743N52	120pF
C352	2113743M24	0.1uF
C355	2113743M24	0.1uF
C357	2113743M24	0.1uF
C358	NOT PLACED	
C359	NOT PLACED	
C360	2113743N14	3.3pF
C361	2113743M24	0.1uF
C362	2113743M24	0.1uF
C364	2113743N35	24pF
C366	NOT PLACED	
C367	2113743N37	30pF
C370	2109445U18	4.3pF 1%
C371	NOT PLACED	
C372	2113743N50	100pF
C373	NOT PLACED	
C374	2113743N50	100pF
C375	2113743N50	100pF
C378	NOT PLACED	
C380	2113743L41	0.01uF
C381	NOT PLACED	
C382	2311049A59	10uF
C383	NOT PLACED	
C385	2113743N35	24pF
C386	2113743N50	100pF
C390	NOT PLACED	
C400	2113743L41	0.01uF
C401	2113743M24	0.1uF
C402	2113743M24	0.1uF
C403	2113743G24	2.2uF
C404	NOT PLACED	
C405	2113743N50	100pF
C406	NOT PLACED	
C407	2113928N01	0.1uF
C408	2113743N50	100pF

Circuit Ref	Motorola Part No.	Description	Circuit Ref	Motorola Part No.	Description	Circuit Ref	Motorola Part No.	Description	Circuit Ref	Motorola Part No.	Description
C409	2113743M24	0.1uF	C481	2113928N01	0.1uF	CR501	4880107R01	Rectifier	L273	2462587V32	68nH
C410	2113928N01	0.1uF	C482	2113928N01	0.1uF	CR503	4805729G49	LED Red/Yellow	L281	2462587V41	390nH
C411	2113743M24	0.1uF	C490	2113743N50	100pF	E101	2484657R01	Ferrite bead	L282	2462587V41	390nH
C414	2113743M24	0.1uF	C491	2113743N50	100pF	E400	2480640Z01	Ferrite bead	L301	2479990B01	11.03nH
C415	2185895Z01	0.01uF	C492	2113743N50	100pF	E401	2480640Z01	Ferrite bead	L302	2479990B01	11.03nH
C416	2113928N01	0.1uF	C493	2113743N50	100pF	E402	2480640Z01	Ferrite bead	L303	2462587V26	22nH
C419	NOT PLACED		C494	2113743N50	100pF	E403	2480640Z01	Ferrite bead	L304	2462587V37	180nH
C420	2113743L41	0.01uF	C495	2113743N50	100pF	E404	2480640Z01	Ferrite bead	L305	2462587V23	12nH
C421	2113928N01	0.1uF	C496	2113743N50	100pF	E405	2480640Z01	Ferrite bead	L306	2479990B01	11.03nH
C422	2113743M24	0.1uF	C497	2113743N50	100pF	E406	2480640Z01	Ferrite bead	L307	2479990B01	11.03nH
C423	2113743N50	100pF	C502	2311049A05	0.47uF	E407	2480640Z01	Ferrite bead	L309	2479990C02	16.28nH
C424	2311049A59	10uF	C503	2113743N50	100pF	E408	2480640Z01	Ferrite bead	L310	2462587V36	150nH
C425	2113743M24	0.1uF	C505	2113743N50	100pF	E409	2480640Z01	Ferrite bead	L311	2413926K32	560nH
C426	2113743N50	100pF	C511	2113743N50	100pF	F501	6580542Z01	3A fuse	L321	2462587V37	180nH
C427	2113743N50	100pF	C512	2113743N50	100pF	FL201	4805875Z04	16.8MHz Xtal oscillator	L325	2462587N68	1uH
C428	2113743M24	0.1uF	C513	2113743N50	100pF	FL301	9180022M11	Xtal Filter 44. 85MHz	L330	2413926K33	680nH
C429	2113743M24	0.1uF	C514	2113743N50	100pF	FL302	9180468V05	455kHz 4- pole ceramic filter	L332	2413923A25	1.2uH
C430	2113928N01	0.1uF	C520	2113743L41	0.01uF	FL303	9180469V05	455kHz 6- pole ceramic filter	L400	2462587Q42	390nH
C431	2113743N50	100pF	C521	2113743L41	0.01uF	FL304	9180469V03	455kHz 6- pole ceramic filter	L401	2462587Q42	390nH
C432	NOT PLACED		C522	2113743L41	0.01uF	FL401	4870368G02	Xtal Oscillator 38.4kHz (Not placed in GP328)	L410	2462587Q42	390nH
C433	2113743L41	0.01uF	C523	2113743L41	0.01uF	H101	2680499Z01	Heat spreader	L411	2462587Q42	390nH
C434	2113928N01	0.1uF (Not placed in GP328)	C524	2113743N50	100pF	J101	0985613Z01	RF Jack	L505	2462587Q42	390nH
C435	2113743M24	0.1uF	C525	2113743N50	100pF	J102	0280519Z02	Antenna nut	P100	3905643V01	Ground contact finger
C436	2113743N34	22pF (Not placed in GP328)	C526	2113743N50	100pF	J400	0905505Y04	40-pin connector	PB501	4086470Z01	Tactile switch, pushbutton
C437	2113743N34	22pF (Not placed in GP328)	C527	2113743N50	100pF	J403	0905505Y02	20-pin connector	PB502	4086470Z01	Tactile switch, pushbutton
C440	2113743G26	4.7uF	C528	2113743N50	100pF	L101	2460591B28	13.37nH	PB503	4086470Z01	Tactile switch, pushbutton
C441	2113743N50	100pF	C529	2113743N50	100pF	L102	2460591B28	13.37nH	PB504	4086470Z01	Tactile switch, pushbutton
C442	2113743E20	0.1uF	CR101	4880973Z02	Pin diode	L104	2460591B48	15.22nH	PB505	4086470Z01	Tactile switch, pushbutton
C443	2113928N01	0.1uF	CR102	4802245J41	Pin diode	L105	2462587N22	390nH	Q110	4813828A09	RF PA
C444	2113743N50	100pF	CR103	4802245J41	Pin diode	L106	2460591A19	8.71nH	Q111	4809939C05	Dual NPN/ PNP transistor
C445	2113743N50	100pF	CR105	5185963A15	Temperature sensor	L107	2479990G01	33.47nH	Q210	4809939C05	Dual NPN/ PNP transistor
C447	2113743M08	0.022uF	CR160	NOT PLACED		L108	2479990A01	4.22nH	Q241	4805218N63	RF NPN transistor
C448	2113928N01	0.1uF	CR201	4802233J09	Triple diode (SOT 25)	L112	2462587N42	12nH	Q260	4809939C05	Dual NPN/ PNP transistor
C449	2113743N50	100pF	CR203	4862824C03	Varactor	L113	2413926H09	5.6nH	Q261	4809939C05	Dual NPN/ PNP transistor
C450	NOT PLACED		CR241	4805649Q13	Varactor	L114	2462587N42	12nH	Q301	4802245J44	NPN Transistor
C451	2113743M08	0.022uF	CR242	4862824C01	Varactor	L115	2462587N22	390nH	Q302	4802197J95	NPN Transistor
C452	2113743B29	1uF	CR243	4862824C01	Varactor	L116	2479990C02	16.28nH	Q310	4802245J44	NPN Transistor
C453	2113743N50	100pF	CR251	4802245J22	Varactor	L117	2409154M17	22nH	Q320	4813824A10	RF NPN transistor
C456	2113743N50	100pF	CR301	4862824C01	Varactor	L160	2413926H14	15.0nH	Q400	4809579E18	Mosfet P - channel
C458	2113743N50	100pF	CR302	4862824C01	Varactor	L201	2462587Q20	2.2uH	Q403	4813824A17	Bipolar Transistor, PNP
C459	2113743N50	100pF	CR303	4880154K03	Dual common anode-cathode	L202	2462587Q20	2.2uH	Q405	4802245J54	Dual NPN Transistor
C463	2113743N50	100pF	CR304	4862824C01	Varactor	L203	2462587Q20	2.2uH	Q410	4802245J54	Dual NPN Transistor
C466	2113743N50	100pF	CR305	4862824C01	Varactor	L232	2462587P25	12uH	Q416	4809579E18	Mosfet P-channel (Not placed in GP328)
C467	2113928N01	0.1uF	CR306	4802245J42	Ring Quad diode (SOT- 143)	L241	2462587V41	390nH	Q417	4809939C05	Dual NPN/ PNP transistor
C471	2113743N50	100pF	CR311	4813825A19	Diode Schottky	L242	2462587V26	22nH	Q502	5180159R01	Dual Trans NPNS
C472	2113743L09	470pF	CR312	4802245J97	Switch Diode	L243	2485776Z02	Resonator (Kapton), Rx	Q505	4880214G02	NPN Transistor
C473	2113743L09	470pF	CR313	4802245J97	Switch Diode	L251	2462587V41	390nH	R101	0662057A34	240
C475	2113743H14	10uF	CR411	4802245J62	Diode Schottky	L253	2460593C03	Resonator, Tx	R102	0680539Z01	0.1
C476	2113928D08	10uF	CR412	4802245J62	Diode Schottky	L261	2462587V29	39nH	R104	0662057N15	47K
C479	2113928N01	0.1uF	CR413	4802245J62	Diode Schottky	L271	2462587V27	27nH	R106	0662057M26	10
C480	2113928D08	10uF	CR440	4813833C02	Dual common cathode diode						

Circuit Ref	Motorola Part No.	Description
R107	NOT PLACED	
R108	0662057M92	5.6K
R109	0662057N30	200K
R110	0662057M61	300
R111	0662057M33	20
R112	0662057M61	300
R120	0662057N14	43K
R130	0662057M98	10K
R131	0662057N05	18K
R132	0662057N33	270K
R133	NOT PLACED	
R136	NOT PLACED	
R161	0662057M57	200
R170	0662057A34	240
R171	0662057N14	43K
R172	0662057A32	200
R173	0662057N29	180K
R174	0662057N15	47K
R175	0662057B59	3
R176	0662057B59	3
R191	0662057C01	0
R201	0662057N21	82K
R202	0662057N23	100K
R204	0662057N15	47K
R231	0662057M52	120
R232	0662057M69	620
R233	0662057M68	560
R241	0662057M34	22
R242	0662057M52	120
R243	0662057M98	10K
R244	0662057N03	15K
R245	0662057M59	240
R248	0662057M37	30
R251	0662057M38	33
R252	0662057M60	270
R253	0662057M95	7.5K
R254	0662057M96	8.2K
R255	0662057M89	4.3K
R256	0662057M37	30
R260	0662057M74	1K
R281	NOT PLACED	
R301	0662057N23	100K
R302	0662057N23	100K
R303	0662057M78	1.5K
R304	0662057N01	12K
R305	0662057M66	470
R306	0662057N23	100K
R307	0662057N23	100K
R308	0662057M43	51
R309	0662057M01	0
R310	NOT PLACED	

Circuit Ref	Motorola Part No.	Description
R311	0662057N11	33K
R312	0662057M90	4.7K
R313	0662057M62	330
R314	0662057M79	1.6K
R315	0662057N01	12K
R320	NOT PLACED	
R321	0662057N01	12K
R322	0662057M74	1K
R324	0662057N25	120K
R328	0662057M12	2.7
R329	0662057M01	0
R330	0662057M98	10K
R331	0662057M57	200
R332	0662057N01	12K
R333	NOT PLACED	
R339	0662057M89	4.3K
R340	0662057M96	8.2K
R342	0662057N23	100K
R344	0662057M43	51
R345	0662057N13	39K
R346	0662057N03	15K
R348	0662057M87	3.6K
R349	0662057C01	0
R350	0662057M98	10K
R355	0662057N23	100K
R358	0662057M74	1K
R359	NOT PLACED	
R360	0662057N06	20K
R361	0662057N06	20K
R363	0662057M64	390
R364	0662057M80	1.8K
R365	0662057M76	1.2K
R366	0662057N01	12K
R367	0662057V04	12K
R368	0662057V02	10K
R369	0662057M70	680
R370	0662057M01	0
R371	NOT PLACED	
R372	NOT PLACED	
R373	NOT PLACED	
R374	NOT PLACED	
R375	NOT PLACED	
R376	NOT PLACED	
R377	NOT PLACED	
R378	NOT PLACED	
R400	0662057N15	47K
R401	0662057M01	0
R402	NOT PLACED	
R403	NOT PLACED	
R405	0662057M01	0
R406	0662057N20	75K

Circuit Ref	Motorola Part No.	Description
R407	0662057N19	68K
R408	NOT PLACED	
R409	0662057M98	10K
R410	0662057N23	100K
R411	0662057M98	10K
R413	0662057M01	0
R414	0662057V34	180K
R415	0662057V26	91K
R416	0662057M98	10K
R418	0662057M01	0
R419	0662057M67	510 (Not placed in GP328)
R420	0662057B46	10M (Not placed in GP328)
R421	0662057M81	2K
R423	0662057N39	470K
R424	0662057N12	36K
R425	0662057N10	30K
R426	0662057N35	330K (Not placed in GP328)
R427	0662057M84	2.7K
R428	0662057M10	2.2
R429	0662057N20	75K
R431	0662057N39	470K
R432	0662057N16	51K
R434	0662057M62	330
R435	0662057M81	2K
R436	0662057M01	0
R437	NOT PLACED	
R445	0662057N08	24K
R447	0662057N23	100K
R448	0662057M98	10K
R449	0662057N08	24K
R450	0683962T45	68
R451	0662057N03	15K
R452	0662057N23	100K
R453	NOT PLACED	
R454	NOT PLACED	
R455	NOT PLACED	
R456	0662057M01	0
R457	0662057M98	10K
R460	0662057M90	4.7K
R461	0662057M56	180 (Not placed in GP328)
R462	0662057M98	10K (Not placed in GP328)
R463	0662057M61	300
R471	0662057N06	20K
R472	0662057N12	36K
R473	0662057M26	10
R475	0662057M01	0
R476	0662057N35	330K
R477	0662057M74	1K
R478	0662057M98	10K
R481	0662057N08	24K
R492	0662057M01	0

Circuit Ref	Motorola Part No.	Description
R498	0662057M98	10K
R499	0662057M98	10K
R501	0662057M70	680
R502	0662057M56	180
R505	0662057M98	10K
R506	0662057N15	47K
R507	0662057M01	0
RT400	0680590Z01	Thermistor 33K
S501	4080710Z01	Frequency switch
S502	1880619Z02	Volume/ on- off switch
SH100	2680507Z01	Harmonic Filter shield
SH101	2680510Z01	RF PA shield
SH201	2680511Z01	Synthesizer top shield
SH202	2680511Z01	Synthesizer bottom shield
SH241	2604120G01	Resonators shield
SH242	2680514Z01	VCO Buffer IC shield
SH301	2686583Z01	Receiver front end shield
SH302	2680555Z01	Receiver front end bottom
SH303	2680509Z01	Mixer shield
SH304	2680624Z01	Mixer diode shield
SH322	2686528Z01	IF section shield
SH323	2686527Z01	Crystal Filter shield
SH400	2680505Z01	Controller Memory Shield
SH401	2680506Z01	Controller on-off shield
SH402	2680515Z01	Microprocessor shield
SH403	2680516Z01	Asfic_Cmp/ Audio PA shield
T301	2580541Z02	Balun transformer
T302	2580541Z02	Balun transformer
U101	5185130C65	VHF/ UHF/ 800 MHZ LDMOS
U102	5185765B26	PCIC
U201	5185963A27	LVFRACN Synthesizer IC
U210	5102463J61	Inverter
U211	5102463J61	Inverter
U241	5105750U54	VCO Buffer IC
U247	5105739X05	SOT 5V Regulator
U248	5102463J58	3. 3V Regulator
U301	5186144B01	FM IFIC SA616
U302	5109522E10	LMOS Inverter
U303	NOT PLACED	
U400	5102463J40	3. 3V Regulator
U404	5185130C53	ASFIC_CMP IC
U405	NOT PLACED	
U406	*5102463J59	Flash ROM 128K x 8
U407	*5102463J64	16K x 8 EEPROM
U409	5102226J56	Microprocessor
U410	5102463J57	3. 3V Regulator (Not placed in GP328)
U420	5102463J44	Audio PA
VR432	4805656W08	5. 6V Zener
VR433	4805656W08	5. 6V Zener
VR434	4802245J73	Zener Diode - 6.8V

Circuit Ref	Motorola Part No.	Description
VR439	4880140L17	Zener Diode - 12V
VR440	4802245J73	Zener Diode - 6.8V
VR441	4802245J73	Zener Diode - 6.8V
VR442	4802245J73	Zener Diode - 6.8V
VR443	4802245J73	Zener Diode - 6.8V
VR444	4802245J73	Zener Diode - 6.8V
VR445	4802245J74	Zener Diode - 10V
VR446	4802245J74	Zener Diode - 10V
VR447	4802245J74	Zener Diode - 10V
VR448	4802245J74	Zener Diode - 10V
VR449	4802245J74	Zener Diode - 10V
VR450	4802245J75	Zener Diode - 12V
VR460	4802245J73	Zener Diode - 6.8V
VR501	4813830A18	6.8V Zener
VR506	4802245J73	Zener Diode - 6.8V
Y300	4802245J84	Xtal Oscillator 33.395MHz
Y301	9186145B02	455kHz Ceramic Discriminator
	*8486686Z01	UHF B2 Main PC Board

* Motorola Depot Servicing only

** Not Field Serviceable

Note: Tolerance

Capacitor - 5% unless specified otherwise

Inductor - 10% unless specified otherwise

Resistor - 5% unless specified otherwise

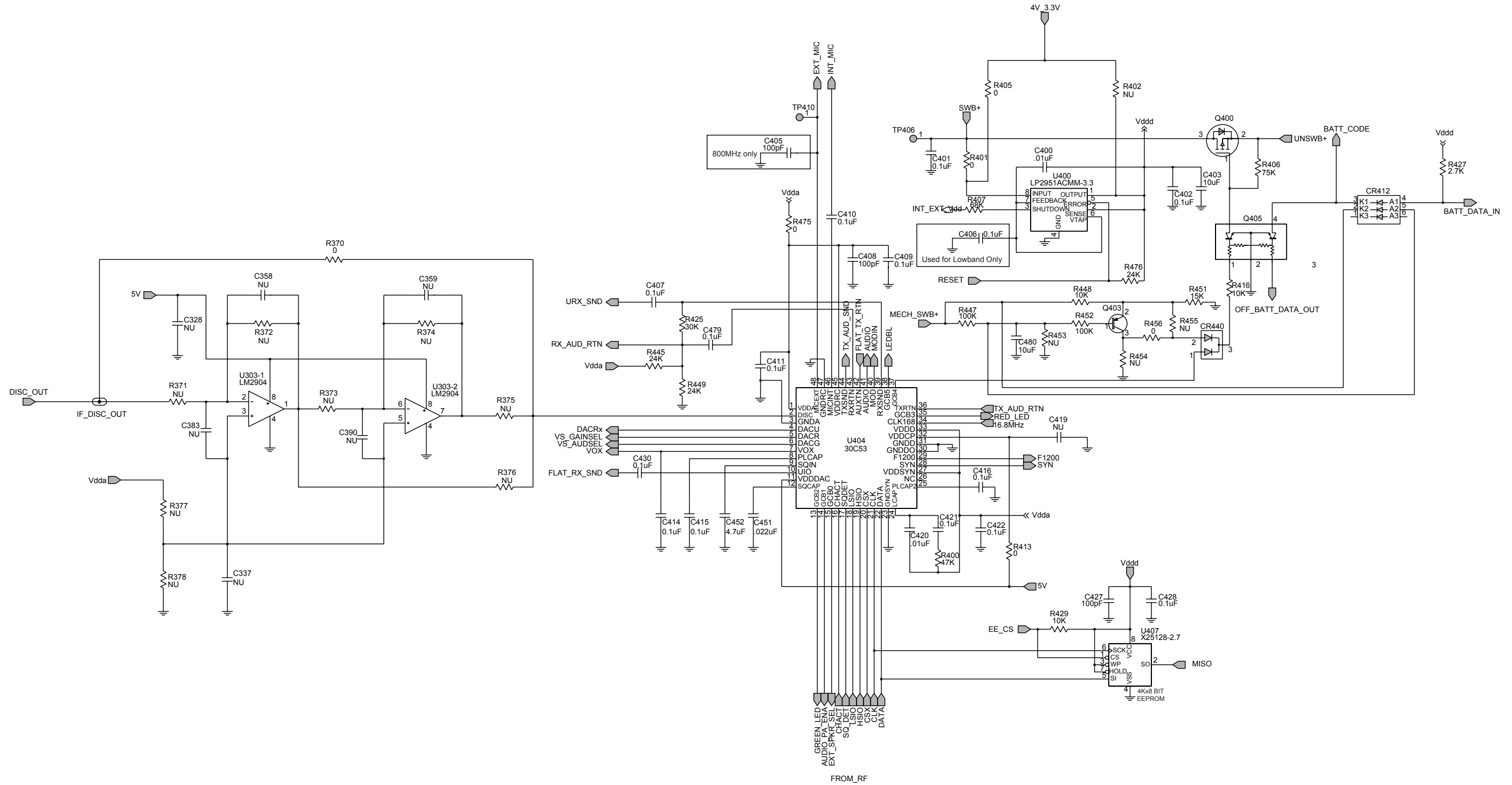
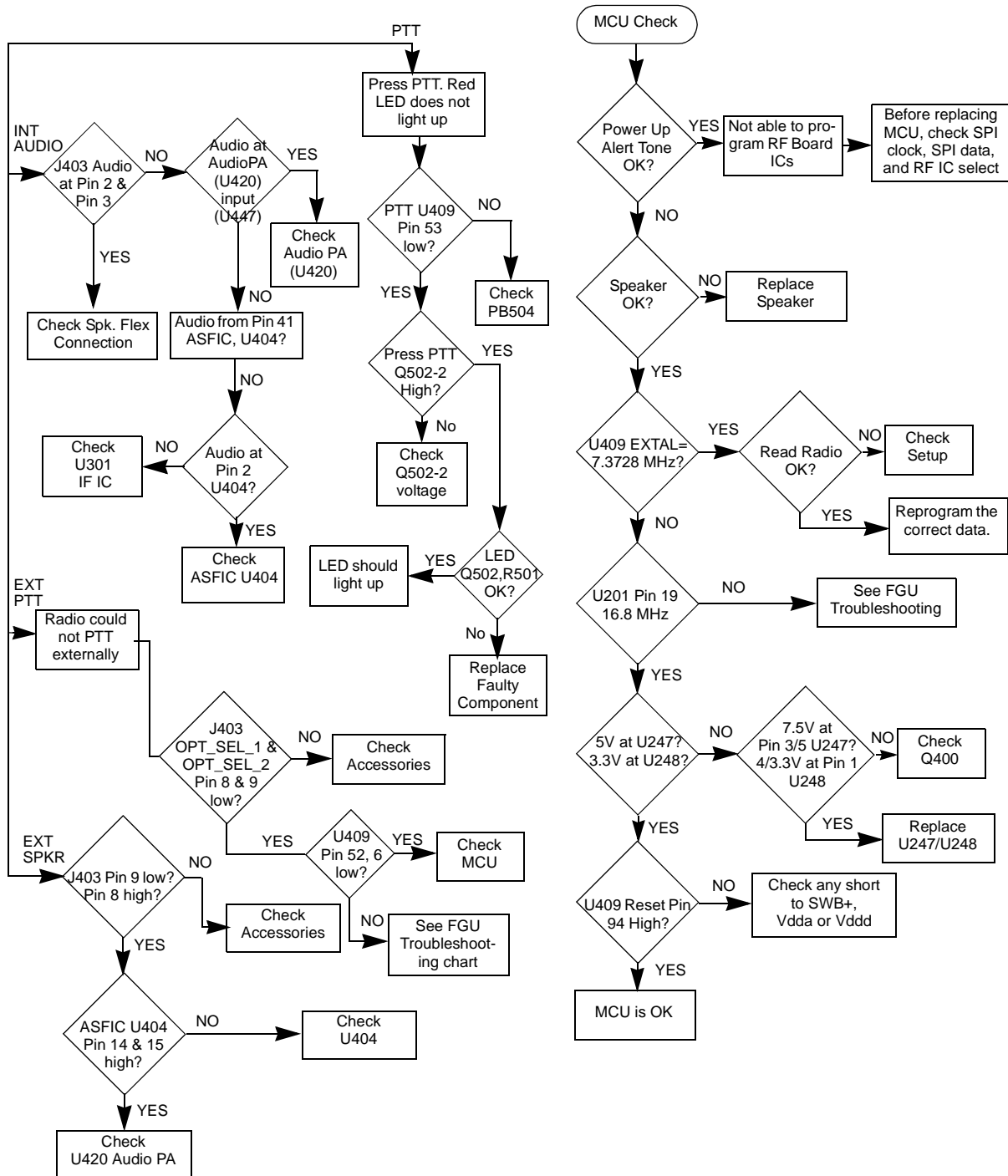

Figure 5-10. Controller ASFIC/ON_OFF Schematic Diagram

Chapter 6 UHF Band 2 Troubleshooting Charts

6.1 Troubleshooting Flow Chart for Controller



6.2 Troubleshooting Flow Chart for Receiver (Sheet 1 of 2)

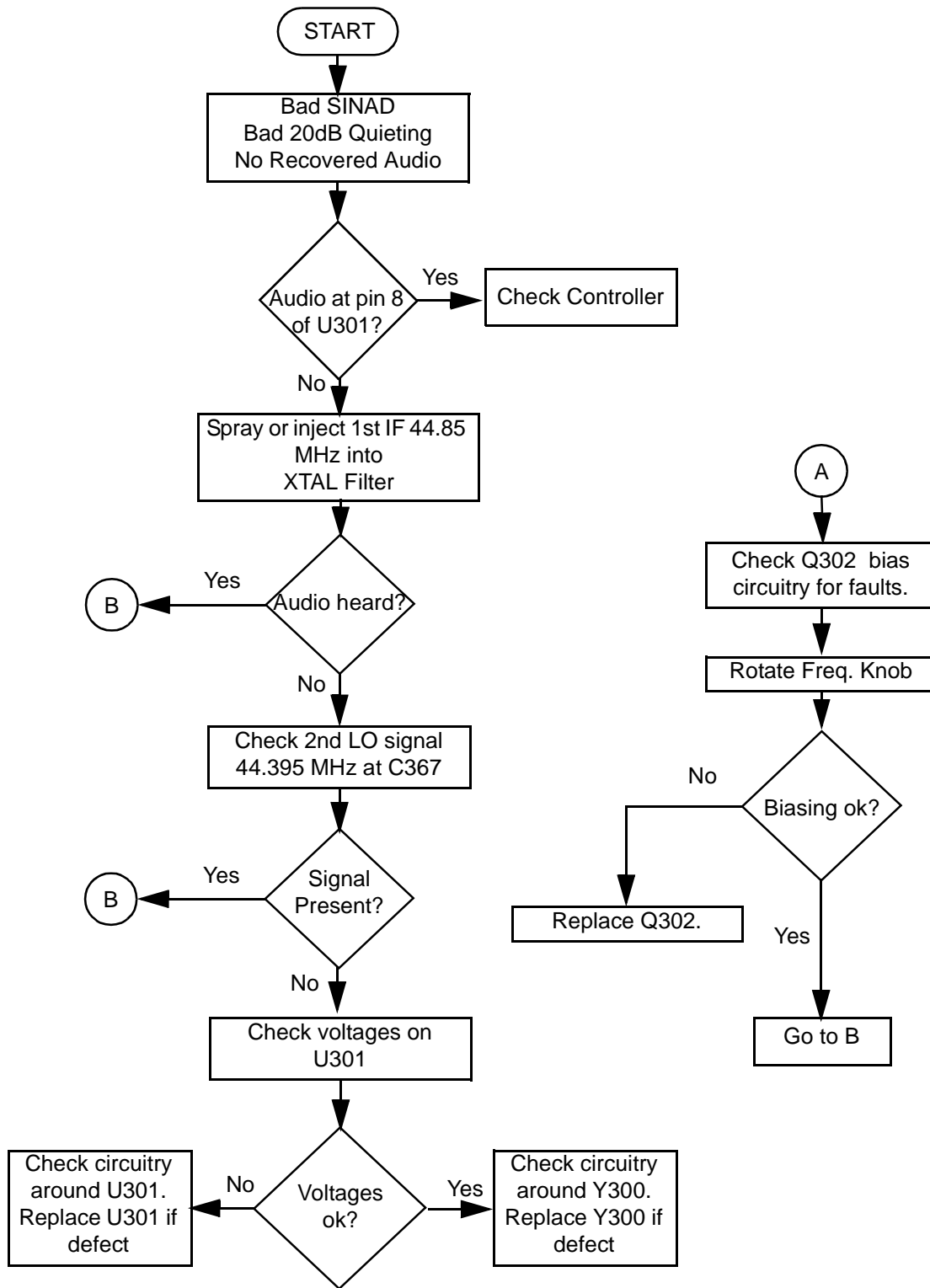

6.3 Troubleshooting Flow Chart for Receiver (Sheet 2 of 2)

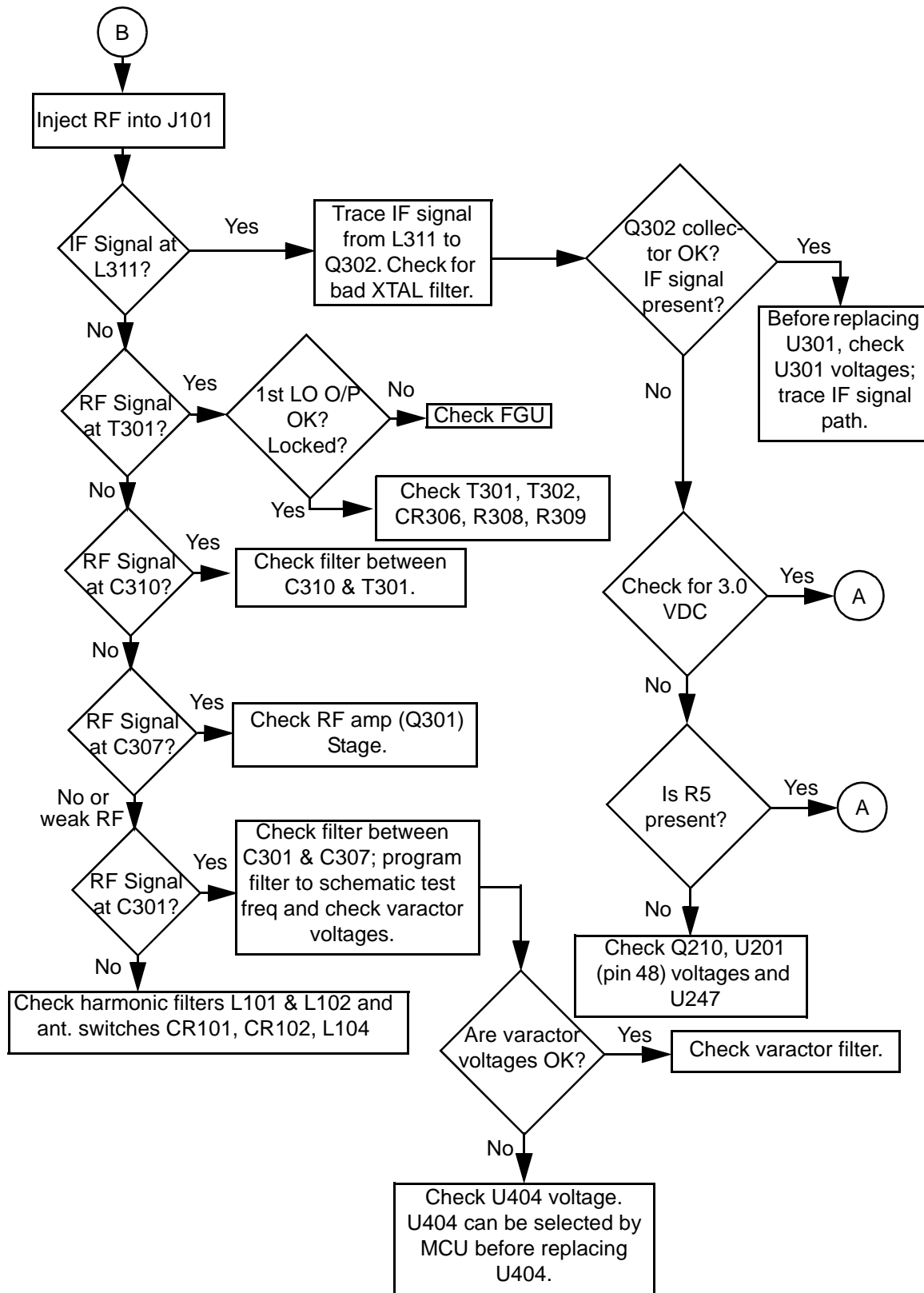

6.4 Troubleshooting Flow Chart for Transmitter

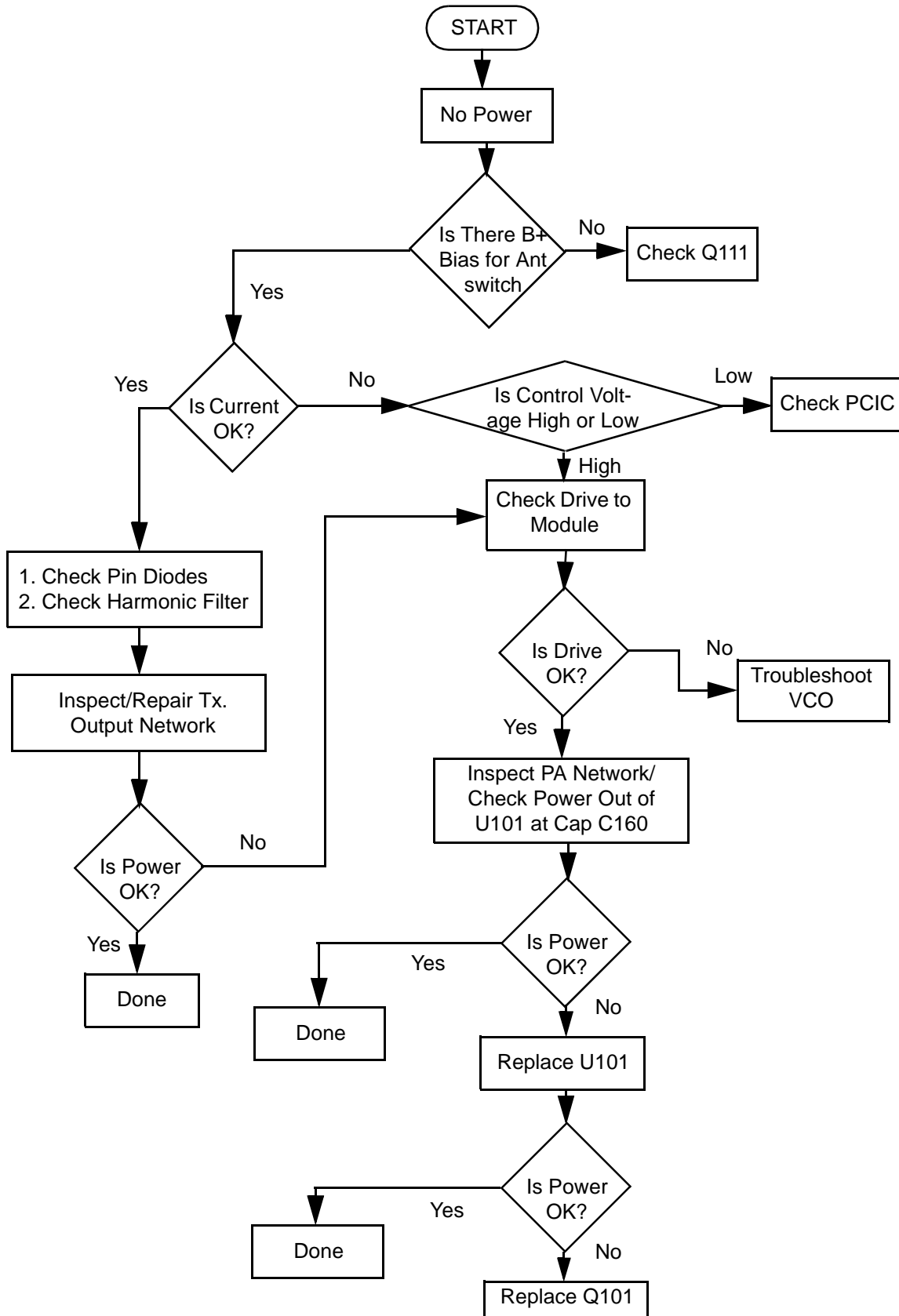

6.5 Troubleshooting Flow Chart for Synthesizer

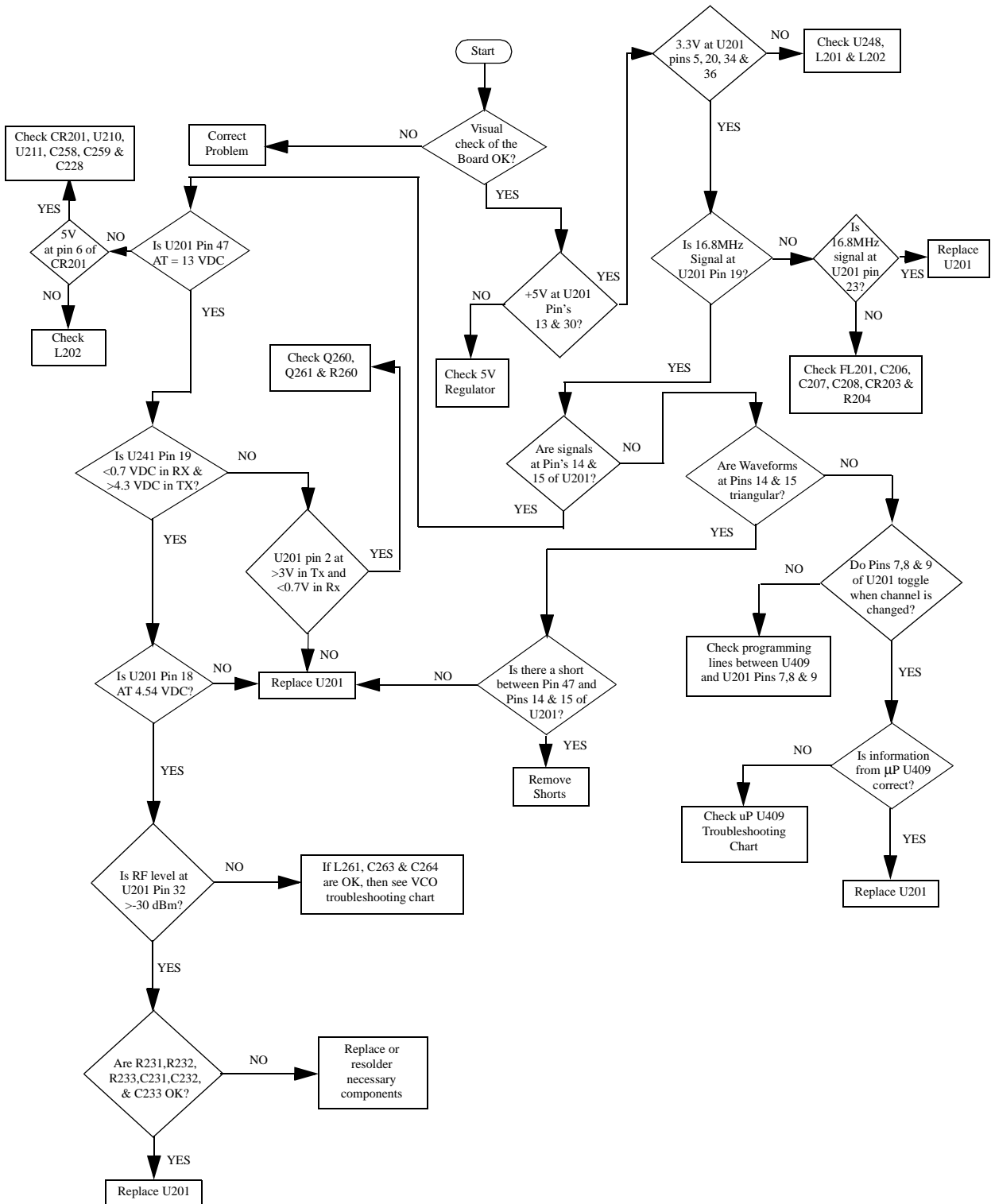

6.6 Troubleshooting Flow Chart for VCO

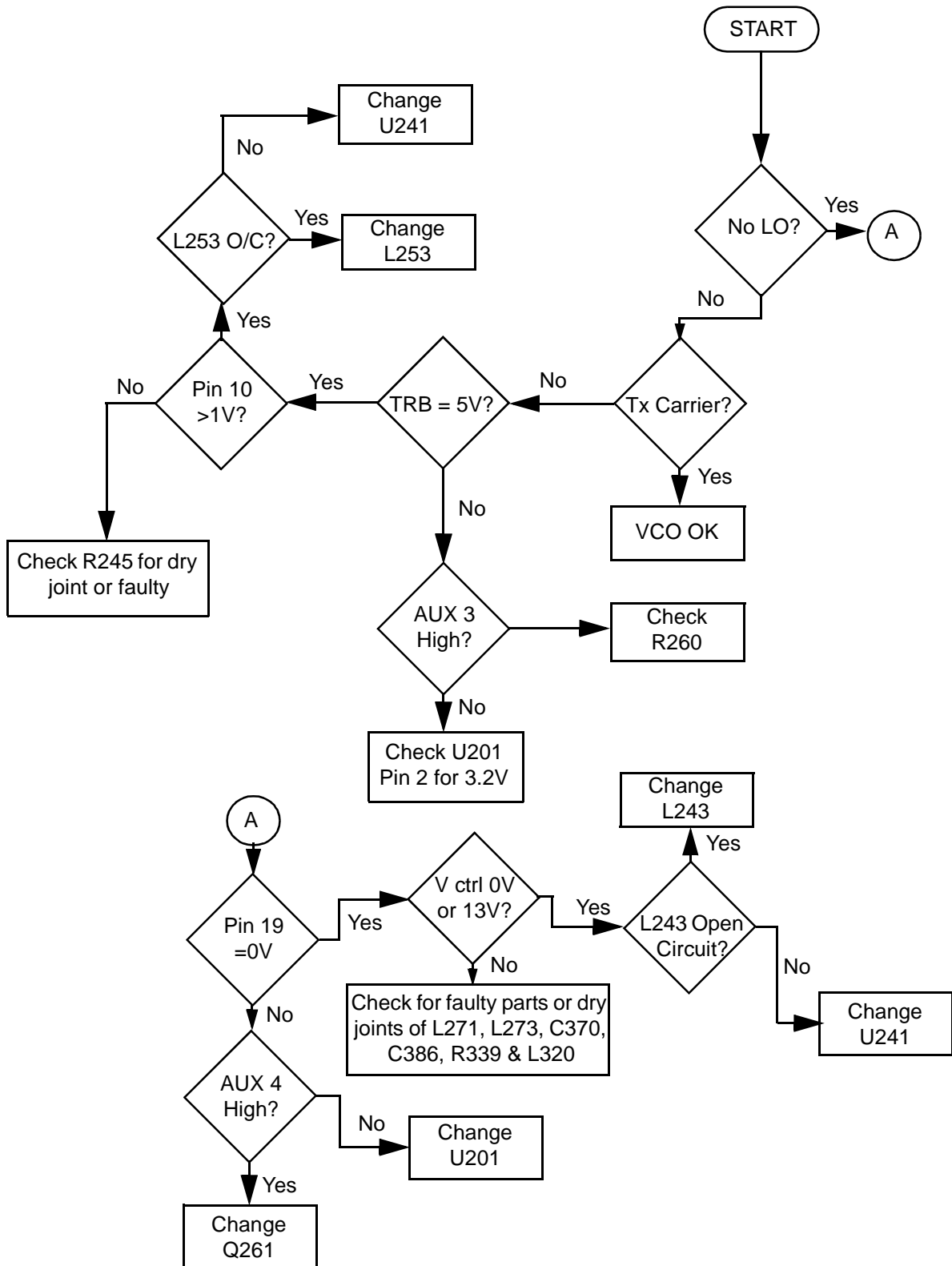

Chapter 7 VHF Theory of Operation

7.1 Transmitter

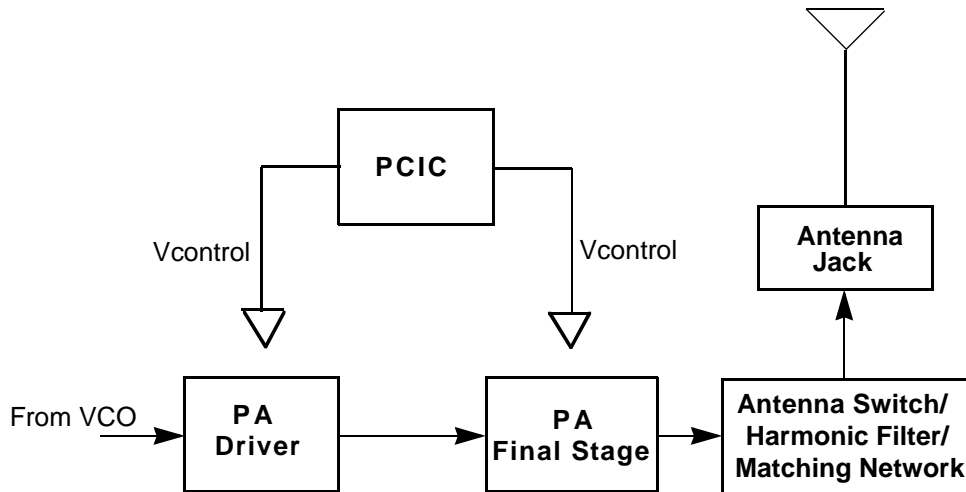

Figure 7-1. Transmitter Block Diagram

7.1.1 General

(Refer to Figure 7-1.)

The VHF transmitter contains five basic circuits:

- Power amplifier
- Antenna switch
- Harmonic filter
- Antenna matching network
- Power control integrated circuit (PCIC)

7.1.2 Power Amplifier

The power amplifier consists of two devices:

- 9Z67 LDMOS driver IC (U3501)
- PRF1507 LDMOS PA (Q3501)

The 9Z67 LDMOS driver IC contains a two-stage amplification with a supply voltage of 7.3V.

This RF power amplifier is capable of supplying an output power of 0.3W (pin 6 and 7) with an input signal of 2mW (3 dBm) (pin16). The current drain would typically be 130mA while operating in the frequency range of 136-174 MHz.

The PRF1507 LDMOS PA is capable of supplying an output power of 7W with an input signal of 0.3W. The current drain would typically be 1800 mA while operating in the frequency range of 136-174 MHz. The power output can be varied by changing the biasing voltage.

7.1.3 Antenna Switch

The antenna switch circuit consists of two PIN diodes (D3521 and D3551), a pi network (C3531, L3551 and C3550), and three current limiting resistors (R3571, R3572, R3573). In the transmit mode, B+ at PCIC (U3502) pin 23 will go low and turn on Q3561 where a B+ bias is applied to the antenna switch circuit to bias the diodes "on." The shunt diode (D3551) shorts out the receiver port, and the pi network, which operates as a quarter wave transmission line, transforms the low impedance of the shunt diode to a high impedance at the input of the harmonic filter. In the receive mode, the diodes are both off, and hence, there exists a low attenuation path between the antenna and receiver ports.

7.1.4 Harmonic Filter

The harmonic filter consists of C3532 to C3536, L3531 and L3532. This network forms a low-pass filter to attenuate harmonic energy of the transmitter to specifications level. The harmonic filter insertion loss should be less than 1.2 dB.

7.1.5 Antenna Matching Network

A matching network which is made up of L3538 and C3537 is used to match the antenna's impedance to the harmonic filter. This will optimize the performance of the transmitter and receiver into an antenna.

7.1.6 Power Control Integrated Circuit (PCIC)

The transmitter uses the Power Control IC (PCIC), U3502 to control the power output of the radio by maintaining the radio current drain. The current to the final stage of the power module is supplied through R3519 (0.1ohms), which provides a voltage proportional to the current drain. This voltage is then fed back to the Automatic Level Control (ALC) within the PCIC to keep the whole loop stable.

The PCIC has internal digital to analog converters (DACs) which provide the reference voltage of the control loop. The voltage level is controlled by the microprocessor through the data line of the PCIC.

There are resistors and integrators within the PCIC, and external capacitors (C3562, C3563 and C3565) in controlling the transmitter rising and falling time. These are necessary in reducing the power splatter into adjacent channels.

U3503 and its associated circuitry acts as a temperature cut back circuitry. This circuitry provides the necessary voltage to the PCIC to cut the transmitter power when the radio temperature gets too high.

7.2 Receiver

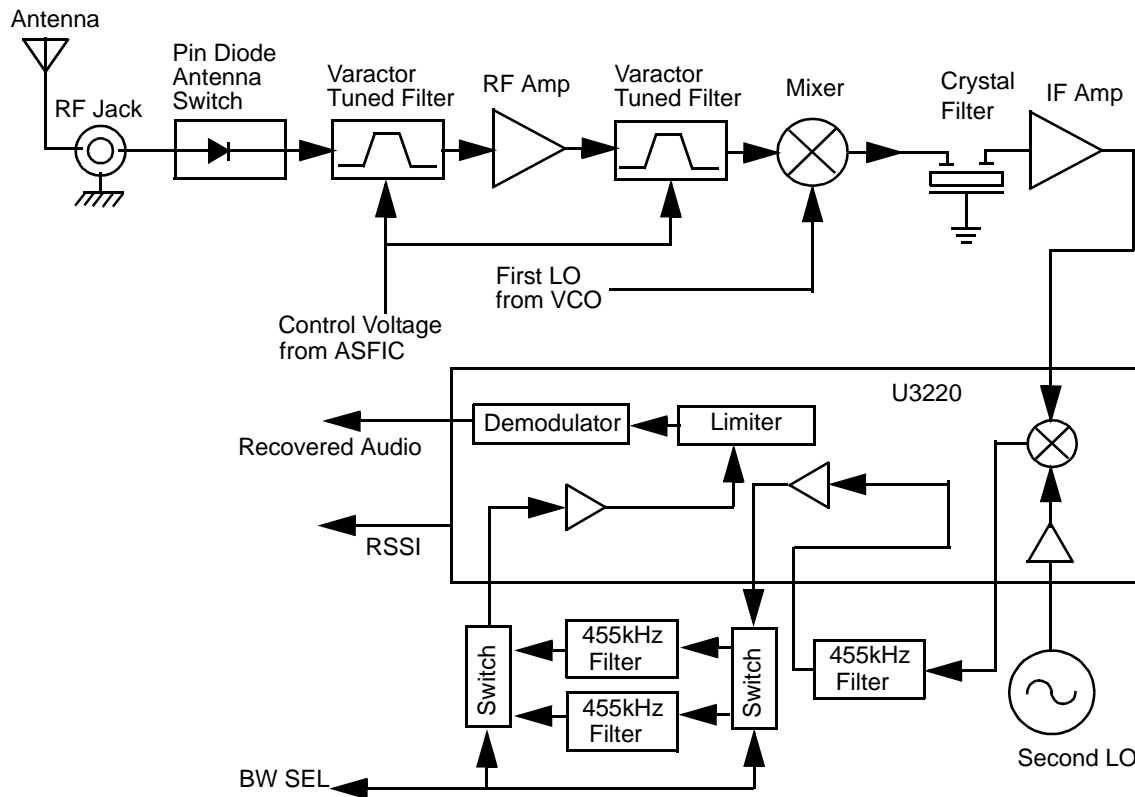

Figure 7-2. VHF Receiver Block Diagram

7.2.1 Receiver Front-End

(Refer to VHF Receiver Front-End Schematic Diagram on page 80, VHF Receiver Back-End Schematic Diagram on page 81, and VHF Transmitter Schematic Diagram on page 84.)

The RF signal is received by the antenna and applied to a low-pass filter. For VHF, the filter consists of L3531, L3532, C3532 to C3563. The filtered RF signal is passed through the antenna switch. The antenna switch circuit consists of two PIN diodes (D3521 and D3551) and a pi network (C3531, L3551 and C3550). The signal is then applied to a varactor tuned bandpass filter. The VHF bandpass filter comprises of L3301, L3303, C3301 to C3304 and D3301. The bandpass filter is tuned by applying a control voltage to the varactor diode (D3301) in the filter.

The bandpass filter is electronically tuned by the DACRx from IC404 which is controlled by the microprocessor. Depending on the carrier frequency, the DACRx will supply the tuned voltage to the varactor diodes in the filter. Wideband operation of the filter is achieved by shifting the bandpass filter across the band.

The output of the bandpass filter is coupled to the RF amplifier transistor Q3302 via C3306. After being amplified by the RF amplifier, the RF signal is further filtered by a second varactor tuned bandpass filter, consisting of L3305, L3306, C3311 to C3314 and D3302.

Both the pre and post-RF amplifier varactor tuned filters have similar responses. The 3 dB bandwidth of the filter is about 12 MHz. This enables the filters to be electronically controlled by using a single control voltage which is DACRx.

The output of the post-RF amplifier filter is connected to the passive double balanced mixer which consists of T3301, T3302 and CR3301. Matching of the filter to the mixer is provided by C3317, C3318 and L3308. After mixing with the first LO signal from the voltage controlled oscillator (VCO) using high side injection, the RF signal is down-converted to the 44.85 MHz IF signal.

The IF signal coming out of the mixer is transferred to the crystal filter (Y3200) through a resistor pad (R3321 - R3323) and a diplexer (C3320 and L3309). Matching to the input of the crystal filter is provided by C3201 and L3200. The crystal filter provides the necessary selectivity and intermodulation protection.

7.2.2 Receiver Back-End

(Refer to *VHF Receiver Back-End Schematic Diagram* on page 81.)

The output of crystal filter Y3200 is matched to the input of IF amplifier transistor Q3200 by L3203. Voltage supply to the IF amplifier is taken from the receive 5 volts (R5). The IF amplifier Q3200 is actively biased by a collector base feedback provided by R3202 and R3203. The gain controlled IF amplifier provides a maximum gain of about 16dB. A dual hot carrier diode (CR3201) limits the filter output voltage swing to reduce overdrive effects at RF levels above -27dBm. The amplified IF signal is then coupled into U3220 (pin 1) via L3202, C3207, and C3200 which provides the matching for the IF amplifier and U3220.

The IF signal applied to pin 1 of U3220 is amplified, down-converted, filtered, and demodulated, to produce the recovered audio at pin 7 of U3220.

Within U3220, the first IF 44.85 MHz signal mixes with the 44.395 MHz second local oscillator (2nd LO) to produce the second IF signal at 455 kHz. The 2nd LO signal frequency is determined by crystal Y3201. The second IF signal (455 kHz) is then filtered by an external ceramic filter Y3205 before being amplified by the second IF amplifier within U3220. Again, the signal is filtered by a second external ceramic filter Y3203 or Y3204 depending on the selected channel spacing. Y3203 is used for 20/25 kHz channel spacing whereas Y3204, for 12.5 kHz channel spacing. The simple circuit consisting of U3221, CR3202, CR3203 and resistors R3209, R3212, R3211 and R3205 divert the second IF signal according to the BW_SEL line. The filtered output of the second IF signal is applied to the limiter input pin of U3220 (Pin 14).

The IF IC (U3220) contains a quadrature detector using a ceramic phase-shift element (Y3202) to provide audio detection. Internal amplification provides an audio output level around 120mVrms (@60% deviation) from pin 8 of U3220. This demodulated audio is fed to the ASFIC_CMP IC (U404) in the controller section.

The IF IC (U3220) also performs several other functions. It provides a received signal-strength indicator (RSSI) with a dynamic range of 70 dB. The RSSI is a dc voltage monitored by the microprocessor, and used as a peak indicator during the bench tuning of the receiver front-end varactor filter.

7.2.3 Automatic Gain Control Circuit

(Refer to *VHF Receiver Front-End Schematic Diagram* on page 80 and *VHF Receiver Back-End Schematic Diagram* on page 81.)

The front-end automatic gain control circuit provides automatic reduction of gain, of the front-end RF amplifier via feedback. This action is necessary to prevent overloading of back-end circuits. This is achieved by drawing some of the output power from the RF amplifier output. At high radio frequencies, capacitor C3327 provides the low impedance path to ground for this purpose. CR3302 is a PIN diode used for switching the path on or off. A certain amount of forward biasing current is needed to turn the PIN diode on. Transistor Q3301 provides this current.

Radio signal strength indicator, RSSI, a voltage signal, is used to drive Q3301 to saturation i.e. turned on. RSSI is produced by U3220 and is proportional to the gain of the RF amplifier and the input power to the radio.

Resistors R3304 and R3305 are voltage dividers designed to turn on Q3301 at certain RSSI levels. In order to turn on Q3301 the voltage across R3305 must be greater or equal to the voltage across R3324, plus the base-emitter voltage (V_{be}) present at Q3301. Capacitor C3209 is used to dampen any instability while the AGC is turning on. The current flowing into the collector of Q3301, a high current gain NPN transistor, will be drawn through the PIN diode to turn it on. Maximum current flowing through the PIN is limited by the resistors R3316, R3313, R3306 and R3324. C3326 is a feedback capacitor used to provide some stability to this high gain stage.

An additional gain control circuit is formed by Q3201 and its associated circuitry. Resistors R3206 and R3207 are voltage dividers designed to turn on Q3201 at a significantly higher RSSI level than the level required to turn on PIN diode control transistor Q3301. In order to turn on Q3201 the voltage across R3207 must be greater or equal to the voltage across R3208, plus the base-emitter voltage (V_{be}) present at Q3201. As current starts flowing into the collector of Q3201, it reduces the bias voltage at the base of IF amplifier transistor Q3200 and in turn, the gain of the IF amplifier. The gain can be controlled in a range of -30dB up to +10dB.

7.3 Frequency Generation Circuitry

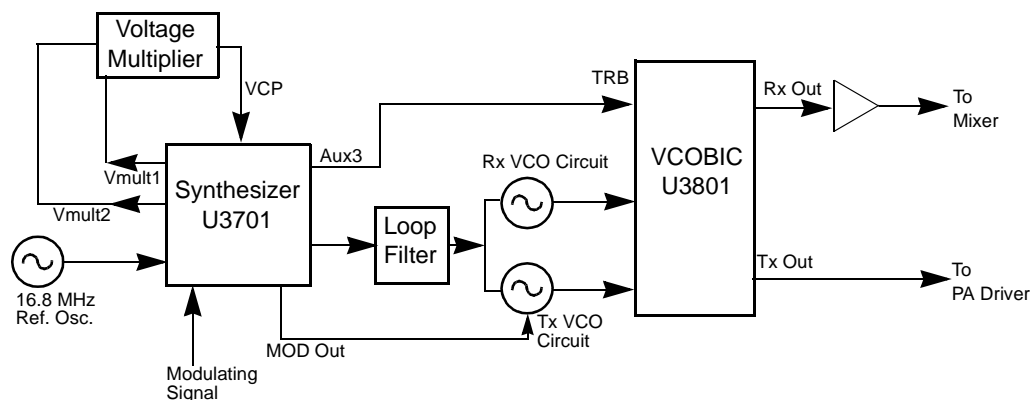

Figure 7-3. Frequency Generation Unit Block Diagram

The Frequency Generation Circuitry is composed of two main ICs, the Fractional-N synthesizer (U3701), and the VCO/Buffer IC (U3801). Designed in conjunction to maximize compatibility, the two ICs provide many of the functions that normally would require additional circuitry. The synthesizer block diagram illustrates the interconnect and support circuitry used in the region. Refer to the relevant schematics for the reference designators.

The synthesizer is powered by regulated 5V and 3.3V which come from U3711 and U3201 respectively. The synthesizer in turn generates a superfiltered 4.5V which powers U3801.

In addition to the VCO, the synthesizer must interface with the logic and ASFIC circuitry. Programming for the synthesizer is accomplished through the data, clock and chip select lines from the microprocessor. A 3.3V dc signal from synthesizer lock detect line indicates to the microprocessor that the synthesizer is locked.

Transmit modulation from the ASFIC is supplied to pin10 of U3701. Internally the audio is digitized by the Fractional-N and applied to the loop divider to provide the low-port modulation. The audio runs through an internal attenuator for modulation balancing purposes before going out to the VCO.

7.4 Synthesizer

(Refer to the *VHF Synthesizer Schematic Diagram* on page 82.)

The Fractional-N Synthesizer uses a 16.8MHz crystal (Y3761) to provide a reference for the system. The LVFractN IC (U3701) further divides this to 2.1MHz, 2.225 MHz, and 2.4 MHz as reference frequencies. Together with C3761, C3762, C3763, R3761 and D3761, they build up the reference oscillator which is capable of 2.5ppm stability over temperatures of -30 to 85°C. It also provides 16.8MHz at pin 19 of U3701 to be used by ASFIC.

The loop filter which consist of C3721, C3722, R3721, R3722 and R3723 provides the necessary dc steering voltage for the VCO and determines the amount of noise and spur passing through.

In achieving fast locking for the synthesizer, an internal adapt charge pump provides higher current at pin 45 of U3701 to put synthesizer within the lock range. The required frequency is then locked by normal mode charge pump at pin 43.

Both the normal and adapt charge pumps get their supply from the capacitive voltage multiplier which is made up of C3701 to C3704 and triple diodes D3701, D3702. Two 3.3V square waves (180 deg out of phase) are first multiplied by four and then shifted, along with regulated 5V, to build up 13.5V at pin 47 of U3701.

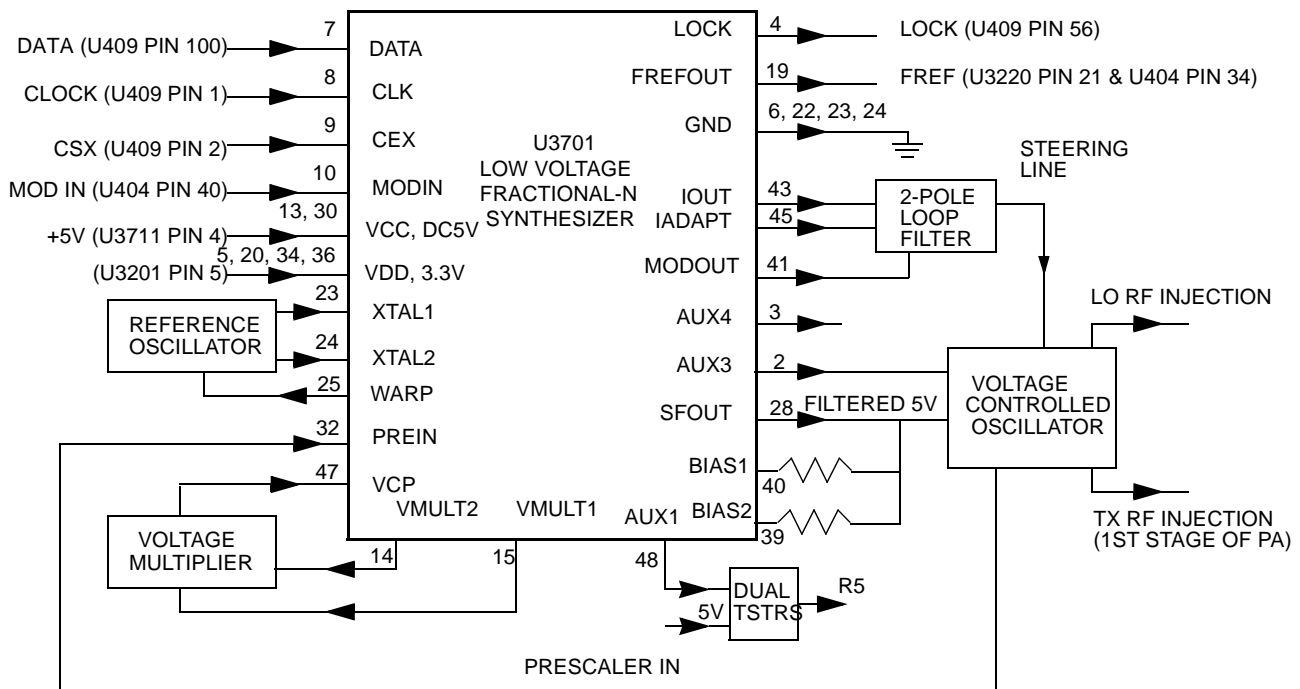

Figure 7-4. Synthesizer Block Diagram

7.5 Voltage-Controlled Oscillator (VCO)

(Refer to the VHF Voltage-Controlled Oscillator Schematic Diagram on page 83.)

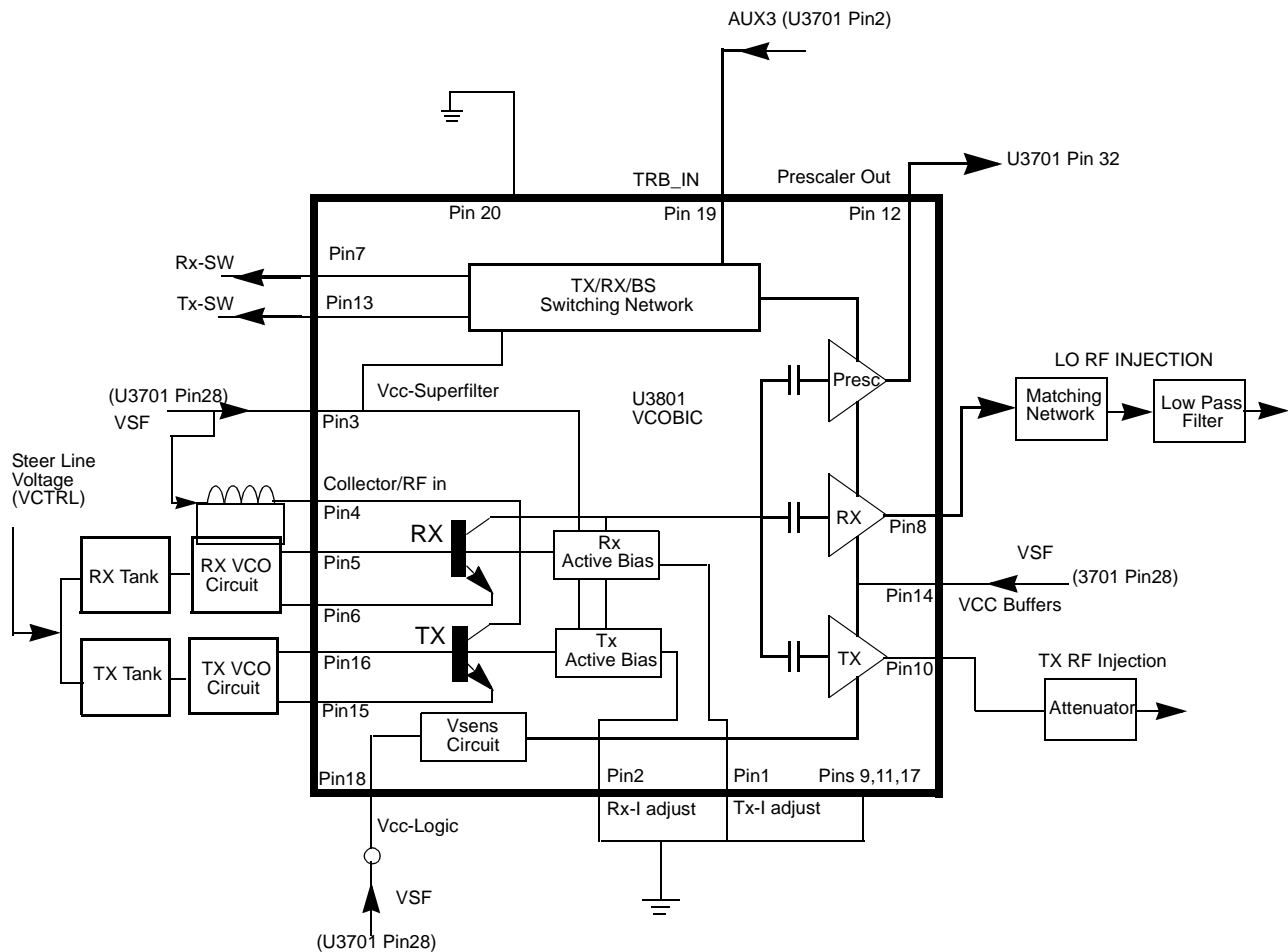

Figure 7-5. VCO Block Diagram

The VCOBIC (U3801) in conjunction with the Fractional-N synthesizer (U3701) generates RF in both the receive and the transmit modes of operation. The TRB line (U3801 pin 19) determines which oscillator and buffer will be enabled. A sample of the RF signal from the enabled oscillator is routed from U3801 pin 12, through a low pass filter, to the prescaler input (U3701 pin 32). After frequency comparison in the synthesizer, a resultant CONTROL VOLTAGE is received at the VCO. This voltage is a DC voltage typically between 3.5V and 9.5V when the PLL is locked on frequency.

The RF section of the VCOBIC(U3801) is operated at 4.54 V (VSF), while the control section of the VCOBIC and Fractional-N synthesizer (U3701) is operated at 3.3V. The operation logic is shown in Table 7-1.

Table 7-1. VCO Control Logic

Desired Mode	AUX 4	AUX 3	TRB
Tx	n.u.	High (@3.2V)	High (@3.2V)
Rx	n.u.	Low	Low
Battery Saver	n.u.	Hi-Z/Float (@1.6V)	Hi-Z/Float (@1.6V)

In receive mode, U3801 pin 19 is low or grounded. This activates the receive VCO by enabling the receive oscillator and the receive buffer of U3801. The RF signal at U3801 pin 8 is run through a matching network. The resulting RF signal is the LO RF INJECTION and it is applied to the mixer at T3302.

During the transmit condition, when PTT is depressed, 3.2 volts is applied to U3801 pin 19. This activates the transmit VCO by enabling the transmit oscillator and the transmit buffer of U3801. The RF signal at U3801 pin 10 is injected into the input of the PA module (U3501 pin16). This RF signal is the TX RF INJECTION. Also in transmit mode, the audio signal to be frequency modulated onto the carrier is received through U3701 pin 41.

When a high impedance is applied to U3801 pin 19, the VCO is operating in BATTERY SAVER mode. In this case, both the receive and transmit oscillators as well as the receive transmit and prescaler buffer are turned off.

Chapter 8 VHF Circuit Board Layouts, Schematic Diagrams and Parts List

8.1 Notes For All Schematics and Circuit Boards

* Component is frequency sensitive. Refer to the Electrical Parts List for value and usage.

1. Unless otherwise stated, resistances are in Ohms ($k = 1000$), and capacitances are in picofarads (pF) or microfarads (μF).
2. DC voltages are measured from point indicated to chassis ground using a Motorola DC multimeter or equivalent. Transmitter measurements should be made with a $1.2 \mu\text{H}$ choke in series with the voltage probe to prevent circuit loading.
3. Reference Designators are assigned in the following manner:
 - 400/500 Series = Controller
 - 600 Series = Keypad Board
 - 3200 Series = IF Circuitry
 - 3300 Series = Receiver
 - 3500 Series = Transmitter
 - 3700 and 3800 Series = Frequency Generation
4. Interconnect Tie Point Legend:
 - UNSWB+ = Unswitch Battery Voltage (7.5V)
 - SWB+ = Switch Battery Voltage (7.5V)
 - R5 = Receiver Five Volts
 - CLK = Clock
 - Vdda = Regulated 3.3 Volts (for analog)
 - Vddd = Regulated 3.3 Volts (for digital)
 - CSX = Chip Select Line
 - SYN = Synthesizer
 - DACRX = Digital-to-Analog Voltage (for Receiver Front-End Filter)
 - VSF = Voltage Super Filtered (5 volts)
 - VR = Voltage Regulator

SIX-LAYER CIRCUIT BOARD DETAIL VIEWING COPPER STEPS IN PROPER LAYER SEQUENCE

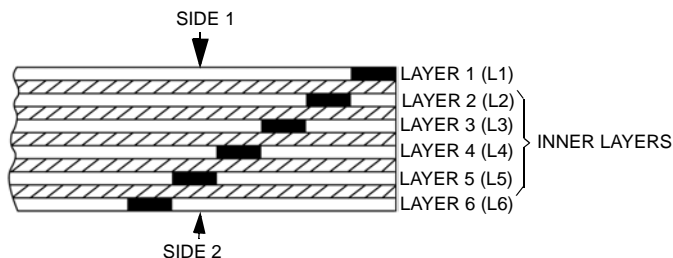

This Page Intentionally Left Blank

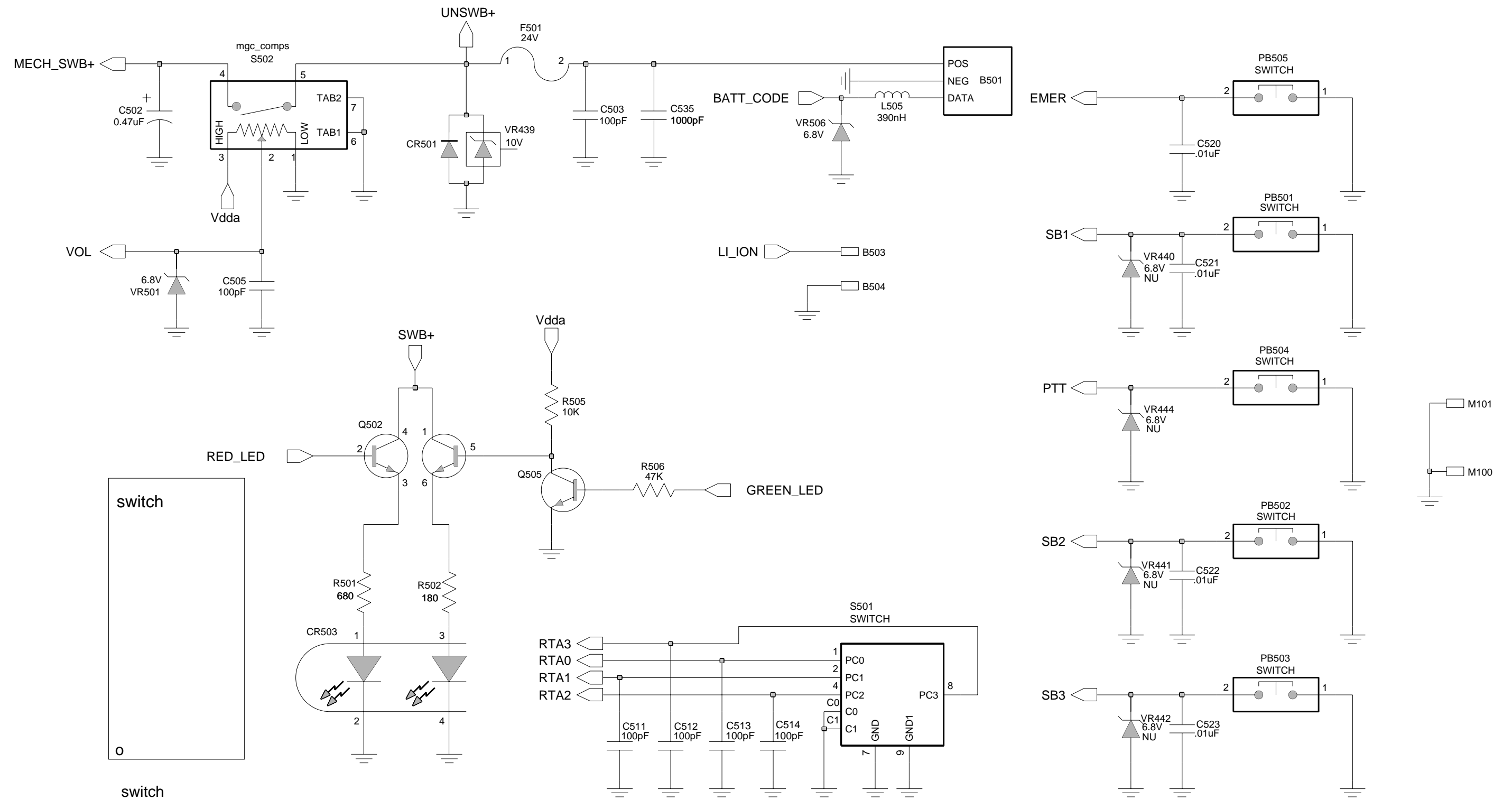

Figure 8-3. VHF Controls And Switches Schematic Diagram

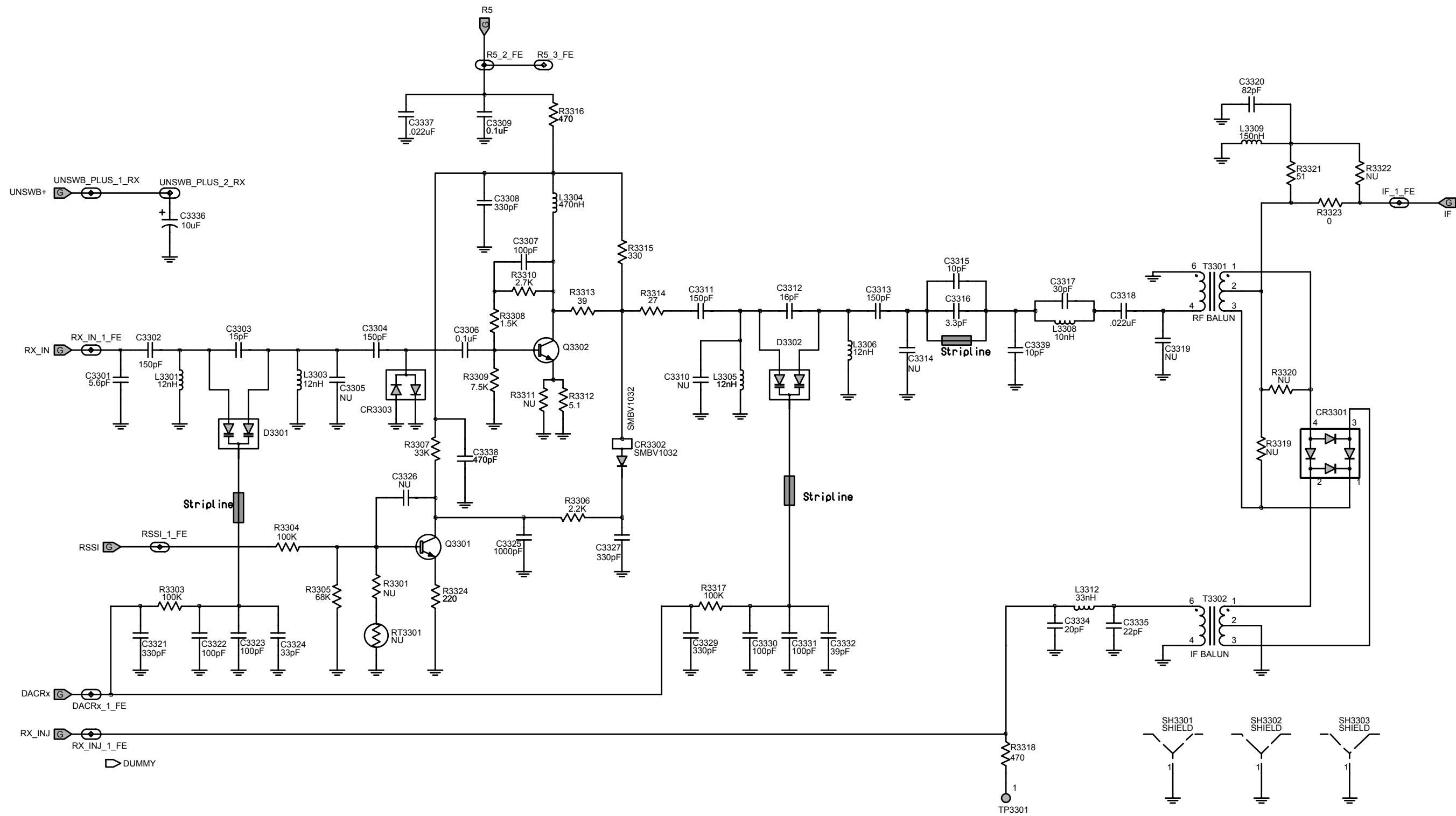

Figure 8-4. VHF Receiver Front-End Schematic Diagram

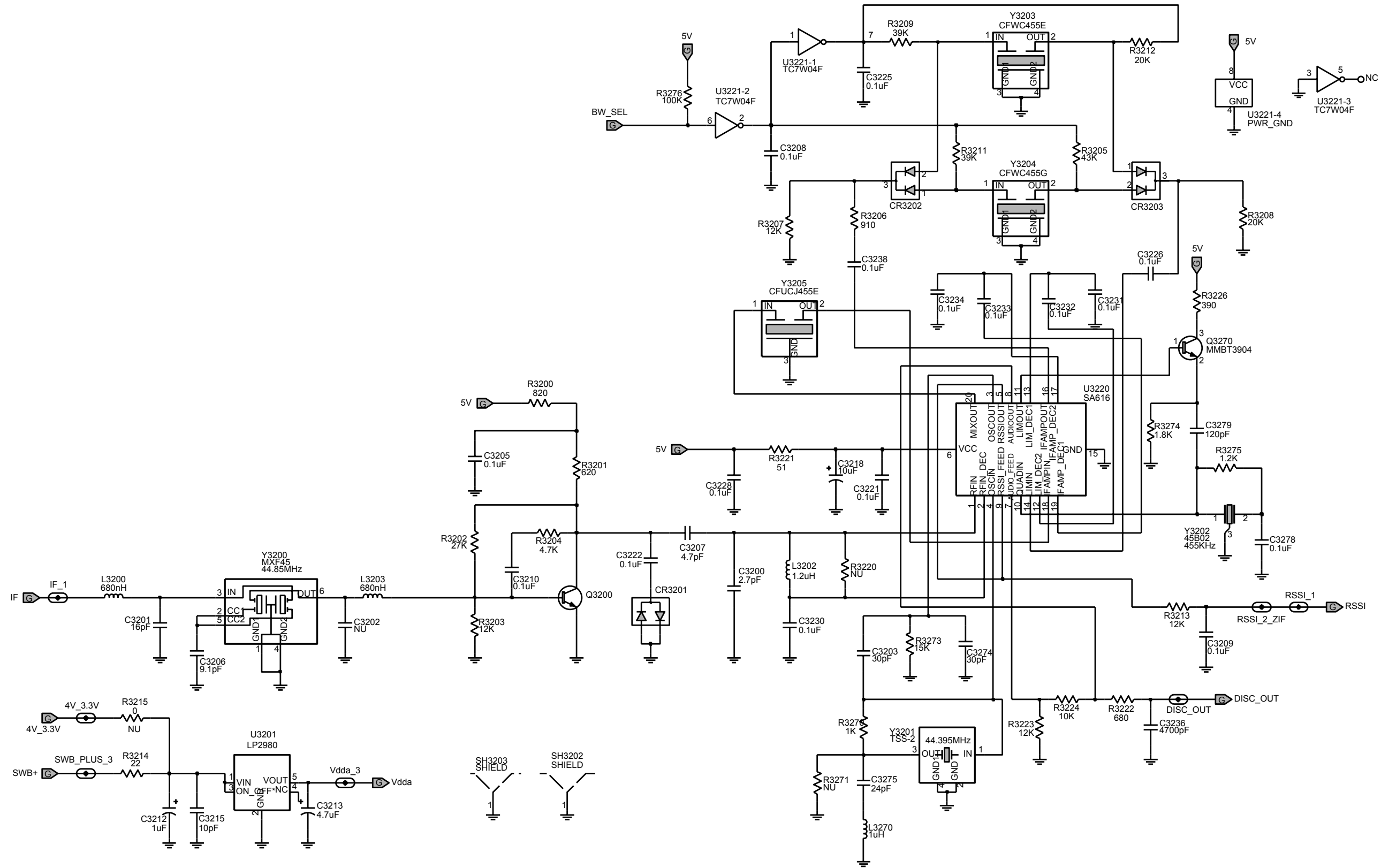

Figure 8-5. VHF Receiver Back-End Schematic Diagram

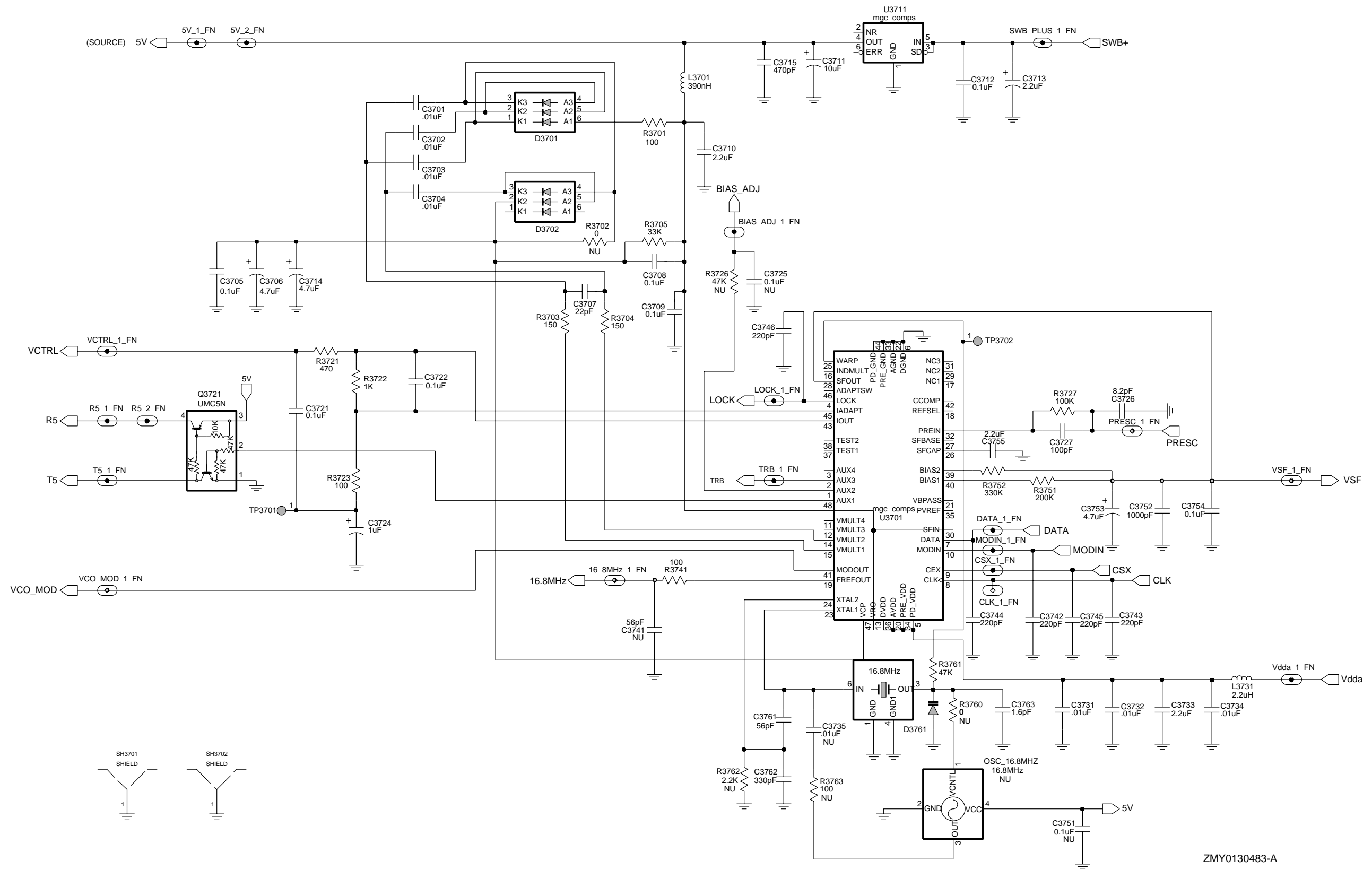

Figure 8-6. VHF Synthesizer Schematic Diagram

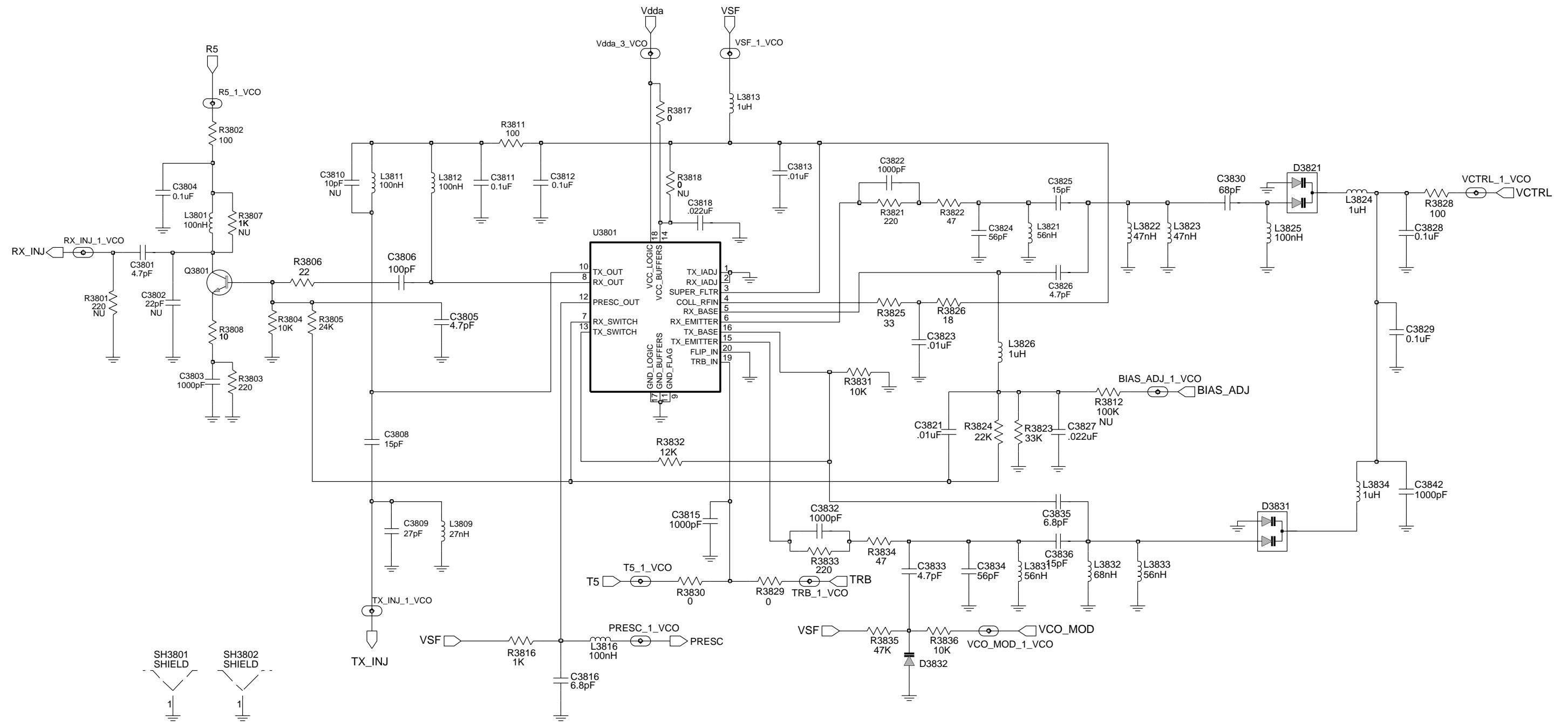

Figure 8-7. VHF Voltage Controlled Oscillator Schematic Diagram

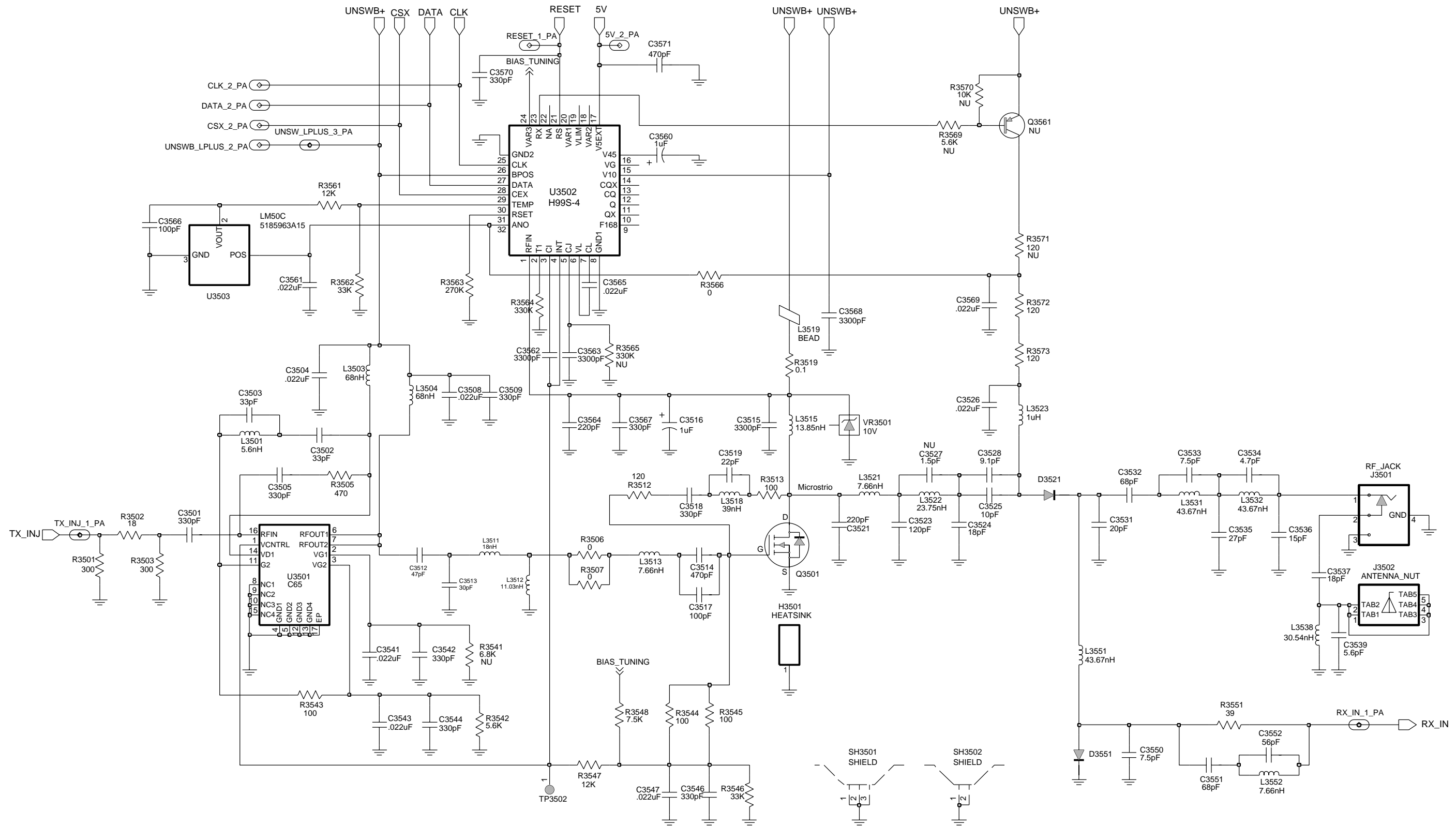

Figure 8-8. VHF Transmitter Schematic Diagram

VHF Radio Parts List

Circuit Ref	Motorola Part No.	Description
B501	0986237A02	Connector (Contact Battery)
B503	3980502Z01	Backup Contact, B+
B504	3980501Z01	Backup Contact, B-
C3200	2113743N12	2.7pF
C3201	2113743N31	16pF
C3202	NOT PLACED	
C3203	2113743N37	30pF
C3205	2113743M24	100nF
C3206	2109445U26	9.1pF 1%
C3207	2113743N18	4.7pF
C3208	2113743M24	100nF
C3209	2113743M24	100nF
C3210	2113743M24	100nF
C3212	2311049A07	1uF
C3213	2311049A56	4.7uF
C3215	2113743N26	10pF
C3218	2311049A59	4.7uF
C3221	2113743E20	0.1uF
C3222	2113743M24	100nF
C3225	2113743M24	100nF
C3226	2113743M24	100nF
C3228	2113743M24	100nF
C3230	2113743M24	100nF
C3231	2113743M24	100nF
C3232	2113743M24	100nF
C3233	2113743M24	100nF
C3234	2113743M24	100nF
C3236	2113743L33	4700pF
C3238	2113743M24	100nF
C3274	2113743N37	30pF
C3275	2113743N35	24pF
C3278	2113743E20	0.1uF
C3279	2113743N52	120pF
C328	2113743M24	100nF
C3301	2113743N20	5.6pF
C3302	2113743N54	150pF
C3303	2113743N30	15pF

Circuit Ref	Motorola Part No.	Description
C3304	2113743N54	150pF
C3305	NOT PLACED	
C3306	2113928N01	0.1uF
C3307	2113743N50	100pF
C3308	2113743L05	330pF
C3309	2113928N01	0.1uF
C3310	NOT PLACED	
C3311	2113743N54	150pF
C3312	2113743N31	16pF
C3313	2113743N54	150pF
C3314	NOT PLACED	
C3315	2113743N26	10pF
C3316	2113743N14	3.3pF
C3317	2113743N37	30pF
C3318	2113743M08	22000pF
C3319	NOT PLACED	
C3320	2113743N48	82pF
C3321	2113743L05	330pF
C3322	2113743N50	100pF
C3323	2113743N50	100pF
C3324	2113743N38	33pF
C3325	2113743L17	1000pF
C3326	NOT PLACED	
C3327	2113743L05	330pF
C3329	2113743L05	330pF
C3330	2113743N50	100pF
C3331	2113743N50	100pF
C3332	2113743N40	39pF
C3334	2113743N33	20pF
C3335	2113743N34	22pF
C3336	2311049A96	33uF
C3337	2113743M08	22000pF
C3338	2113743L09	470pF
C3339	2113743N26	10pF
C337	2113928P04	1uF
C3501	2113743L05	330pF
C3502	2113743N38	33pF
C3503	2113743N38	33pF

Circuit Ref	Motorola Part No.	Description
C3504	2113743M08	22000pF
C3505	2113743N38	33pF
C3508	2113743M08	22000pF
C3509	2113743L05	330pF
C3512	2113740F43	47pF
C3513	2113740F38	30pF
C3514	2113740F47	68pF
C3515	2113743L29	3300pF
C3516	2311049A08	1uF
C3517	2113740F47	68pF
C3518	NOT PLACED	
C3519	NOT PLACED	
C3521	2111078B51	220pF
C3523	2111078B44	120pF
C3524	2113740F34	20pF
C3525	2113740F27	10pF
C3526	2113743M08	22000pF
C3527	NOT PLACED	
C3528	2113740F27	10pF
C3531	2113740F34	20pF
C3532	2113740F47	68pF
C3533	2113740F24	7.5pF
C3534	2113740F19	4.7pF
C3535	2113740F37	27pF
C3536	2113740F31	15pF
C3537	2113740F33	18pF
C3539	2113740F29	12pF
C3541	2113743M08	22000pF
C3542	2113743L05	330pF
C3543	2113743M08	22000pF
C3544	2113743L05	330pF
C3546	2113743L05	330pF
C3547	2113743M08	22000pF
C3550	2113743N23	7.5pF
C3551	2113743N46	68pF
C3552	2113743N44	56pF
C3560	2311049A07	1uF
C3561	2113743M08	22000pF

Circuit Ref	Motorola Part No.	Description
C3562	2113743L29	3300pF
C3563	2113743L29	3300pF
C3564	2113743L01	220pF
C3565	2113743E07	0.022uF
C3566	2113743N50	100pF
C3567	2113743L05	330pF
C3568	2113743L29	3300pF
C3569	2113743M08	22000pF
C3570	2113743L05	330pF
C3571	2113743L09	470pF
C358	2113743N22	6.8pF
C359	2113743N31	16pF
C3701	2113743L41	10000pF
C3702	2113743L41	10000pF
C3703	2113743L41	10000pF
C3704	2113743L41	10000pF
C3705	2113743E20	0.1uF
C3706	2311049J11	4.7uF
C3707	2113743N34	22pF
C3708	2113928N01	0.1uF
C3709	2113928N01	0.1uF
C3710	2104993J02	2.2uF
C3711	2311049A69	10uF
C3712	2113928N01	0.1uF
C3713	2311049A09	2.2uF
C3714	2311049J11	4.7uF
C3715	2113743L09	470pF
C3721	2113743E20	0.1uF
C3722	2113743E20	0.1uF
C3724	2311049A08	1uF
C3725	NOT PLACED	
C3726	2113743N24	8.2pF
C3727	2113743N50	100pF
C3731	2113743L41	10000pF
C3732	2113743L41	10000pF
C3733	2104993J02	2.2uF
C3734	2113743L41	10000pF
C3741	NOT PLACED	

Circuit Ref	Motorola Part No.	Description
C3742	2113743L01	220pF
C3743	2113743L01	220pF
C3744	2113743L01	220pF
C3745	2113743L01	220pF
C3746	2113743L01	220pF
C3752	2113743L17	1000pF
C3753	2311049A56	4.7uF
C3754	2113928N01	0.1uF
C3755	2104993J02	2.2uF
C3761	2113743N42	47pF
C3762	2113740F63	330pF
C3763	NOT PLACED	
C3801	2113743N18	4.7pF
C3802	NOT PLACED	
C3803	2113743L17	1000pF
C3804	2113743E20	0.1uF
C3805	2113743N18	4.7pF
C3806	2113743N50	100pF
C3808	2113743N30	15pF
C3809	2113743N36	27pF
C3810	NOT PLACED	
C3811	2113928N01	0.1uF
C3812	2113928N01	0.1uF
C3813	2113743L41	10000pF
C3815	2113743L17	1000pF
C3816	2113743N22	6.8pF
C3818	2113743E07	0.022uF
C3821	2113743L41	10000pF
C3822	2113743L17	1000pF
C3823	2113743L41	10000pF
C3824	2113743N44	56pF
C3825	2113743N30	15pF
C3826	2113743N18	4.7pF
C3827	2113743E07	0.022uF
C3828	2185895Z01	0.01uF
C3829	2185895Z01	0.01uF
C383	2113743N43	51pF
C3830	2113743N46	68pF

Circuit Ref	Motorola Part No.	Description
C3832	2113743L17	1000pF
C3833	2113743N18	4.7pF
C3834	2113743N44	56pF
C3835	2113743N22	6.8pF
C3836	2113743N30	15pF
C3842	2113743L17	1000pF
C390	2113743N43	51pF
C400	2113743L41	10000pF
C401	2113928N01	0.1uF
C402	2113928N01	0.1uF
C4020	NOT PLACED	
C4021	NOT PLACED	
C403	2113743G24	2.2uF
C407	2113928N01	0.1uF
C408	2113743N50	100pF
C409	2113928N01	0.1uF
C410	2113928N01	0.1uF
C411	2113928N01	0.1uF
C414	2113928N01	0.1uF
C415	2185895Z01	0.01uF
C416	2113928N01	0.1uF
C419	2113743L41	10000pF
C420	2113743L41	10000pF
C421	2113928N01	0.1uF
C422	2113928N01	0.1uF
C423	2113743N50	100pF
C424	2311049A59	10uF
C425	2113928N01	0.1uF
C426	2113743N50	100pF
C427	2113743N50	100pF
C428	2113928N01	0.1uF
C429	2113928N01	0.1uF
C430	2113928N01	0.1uF
C431	2113743N50	100pF
C432	NOT PLACED	
C433	2113743N34	22pF
C434	2113928N01	0.1uF
C435	2113928N01	0.1uF

Circuit Ref	Motorola Part No.	Description
C436	2113743N34	22pF
C437	2113743N34	22pF
C440	2113743G26	4.7uF
C441	2113743L09	470pF
C442	2113743E20	0.1uF
C443	2113928N01	0.1uF
C444	2113743N50	100pF
C445	2113743L09	470pF
C446	2113743L09	470pF
C447	2113928N01	0.1uF
C448	2113928N01	0.1uF
C449	2113743N50	100pF
C450	NOT PLACED	
C451	2113743M08	22000pF
C452	2113743B29	1uF
C453	2113743N50	100pF
C456	2113743N50	100pF
C458	2113743N50	100pF
C459	2113743N50	100pF
C463	2113743N50	100pF
C466	2113743N50	100pF
C467	2113928N01	0.1uF
C471	2113743L09	470pF
C472	2113743L09	470pF
C473	2113743L09	470pF
C474	2113743L41	10000pF
C475	2113743H14	10uF
C476	2113928D08	10uF
C477	2113743L17	1000pF
C478	2113743L17	1000pF
C479	2113928N01	0.1uF
C480	2113928D08	10uF
C481	2113928N01	0.1uF
C482	2113928N01	0.1uF
C483	2113743L09	470pF
C484	2113743L09	470pF
C490	2113743L09	470pF
C491	2113743L09	470pF

Circuit Ref	Motorola Part No.	Description
C492	2113743L09	470pF
C493	2113743N50	100pF
C494	2113743N50	100pF
C495	2113743L09	470pF
C496	2113743L09	470pF
C497	2113743L09	470pF
C502	2311049A05	0.47uF
C503	2113743N50	100pF
C505	2113743N50	100pF
C511	2113743N50	100pF
C512	2113743N50	100pF
C513	2113743N50	100pF
C514	2113743N50	100pF
C520	2113743L41	10000pF
C521	2113743L41	10000pF
C522	2113743L41	10000pF
C523	2113743L41	10000pF
C535	2113743L17	1000pF
CR3201	4813825A19	Schottky Diode
CR3202	4802245J97	Band Switching Diode
CR3203	4802245J97	Band Switching Diode
CR3301	4802245J42	Ring Quad Diode
CR3302	4805129M96	Dual Diode
CR3303	4880154K03	Dual Diode
CR411	4802245J62	Schottkt Diode
CR412	4802245J62	Schottkt Diode
CR413	4802245J62	Schottkt Diode
CR440	4813833C02	Dual Diode
CR501	4880107R01	Rectifier
CR503	4805729G49	Red / Yellow LED
D3301	4802081B58	Dual Diode
D3302	4802081B58	Dual Diode
D3521	4880973Z02	Pin Diode
D3551	4880973Z02	Pin Diode
D3701	4802233J09	Triple Diode
D3702	4802233J09	Triple Diode
D3761	4862824C03	Varactor Diode
D3821	4805649Q13	Varactor Diode

Circuit Ref	Motorola Part No.	Description	Circuit Ref	Motorola Part No.	Description	Circuit Ref	Motorola Part No.	Description	Circuit Ref	Motorola Part No.	Description
D3831	4805649Q13	Varactor Diode	L3515	2479990C03	13.85nH	PB505	4086470Z01	Tactile Switch	R3270	0662057M74	1000
D3832	4862824C01	Varactor Diode	L3518	NOT PLACED		Q3200	4802197J95	NPN Transistor	R3271	NOT PLACED	
E400	2480640Z01	Ferrite Bead	L3519	2484657R01	Ferrite Bead	Q3270	4813824A10	NPN Transistor	R3273	0662057N03	15K
E401	2480640Z01	Ferrite Bead	L3521	2479990A02	7.6nH	Q3301	4880214G02	NPN Transistor	R3274	0662057M80	1800
E402	2480640Z01	Ferrite Bead	L3522	2479990E01	23.75nH	Q3302	4802197J95	NPN Transistor	R3275	0662057M76	1200
E403	2480640Z01	Ferrite Bead	L3523	2462587N68	1000nH	Q3501	4813828A08	RF Power Amplifier	R3276	0662057N23	100K
E404	2480640Z01	Ferrite Bead	L3531	2479990N01	43.67nH	Q3561	4813824A17	PNP Transistor	R3301	NOT PLACED	
E405	2480640Z01	Ferrite Bead	L3532	2479990N01	43.67nH	Q3721	4809939C05	Dual NPN/PNP Transistor	R3303	0662057N23	100K
E406	2480640Z01	Ferrite Bead	L3538	2479990M01	30.54nH	Q3801	4802197J95	NPN Transistor	R3304	0662057N23	100K
E407	2480640Z01	Ferrite Bead	L3551	2479990N01	43.67nH	Q400	4809579E18	MOSFET P-chan Transistor	R3305	0662057N19	68K
E408	2480640Z01	Ferrite Bead	L3552	2479990A02	7.6nH	Q403	4813824A17	PNP Transistor	R3306	0662057M82	2200
E409	2480640Z01	Ferrite Bead	L3701	2462587Q42	390nH	Q405	4802245J54	Dual NPN Transistor	R3307	0662057N11	33K
F501	6580542Z01	Fuse 3A	L3731	2462587Q20	2,200nH	Q410	4802245J54	Dual NPN Transistor	R3308	0662057M78	1500
FL401	4870368G02	Real Time Clock Crystal Oscillator	L3801	2462587V34	100nH	Q416	4809579E18	MOSFET P-chan Transistor	R3309	0662057M95	'7500
H3501	2680499Z01	Heat Spreader	L3809	2462587V27	27nH	Q417	4809939C05	Dual NPN/PNP Transistor	R3310	0662057M84	2700
J3501	0985613Z01	RF Jack	L3811	2462587V34	100nH	Q502	5180159R01	Dual NPN Transistor	R3311	NOT PLACED	
J3502	0280519Z04	Antenna Nut	L3812	2462587V34	100nH	Q505	4880214G02	NPN Transistor	R3312	0662057M19	5.1
J400	0905505Y04	40-Pin Connector	L3813	2462587Q47	1000nH	R3200	0662057M72	820	R3313	0662057M40	39
J403	0905505Y02	20-Pin Connector	L3816	2462587V34	100nH	R3201	0662057M69	620	R3314	0662057M35	24
L3200	2413926K33	680nH	L3821	2462587N50	56nH	R3202	0662057N09	27K	R3315	0662057M62	330
L3202	2413923A25	1200nH	L3822	2462587N49	47nH	R3203	0662057N01	12K	R3316	0662057M66	470
L3203	2413926K33	680nH	L3823	2462587N49	47nH	R3204	0662057M90	4700	R3317	0662057N23	100K
L3270	2462587N68	1000nH	L3824	2462587N68	1000nH	R3205	0662057N06	20K	R3318	0662057M66	470
L3301	2462587T35	12nH	L3825	2462587V34	100nH	R3206	0662057M73	910	R3319	NOT PLACED	
L3303	2462587T35	12nH	L3826	2462587N68	1000nH	R3207	0662057N01	12K	R3320	NOT PLACED	
L3304	2462587T23	470nH	L3831	2462587N50	56nH	R3208	0662057N06	20K	R3321	0662057M43	51
L3305	2462587T35	12nH	L3832	2462587N51	68nH	R3209	0662057N13	39K	R3322	NOT PLACED	
L3306	2462587T35	12nH	L3833	2462587N50	56nH	R3211	0662057N13	39K	R3323	0662057M01	0
L3308	2462587T34	10nH	L3834	2462587N68	1000nH	R3212	0662057N06	20K	R3324	0662057M58	220
L3309	2462587N55	150nH	L400	2462587Q42	390nH	R3213	0662057N01	12K	R3501	0662057M61	300
L3312	2462587V28	33nH	L401	2462587Q42	390nH	R3214	0662057M34	22	R3502	0662057M32	18
L3501	2413926H09	5.6nH	L410	2462587Q42	390nH	R3215	0662057M01	0	R3503	0662057M61	300
L3503	2462587V32	68nH	L411	2462587Q42	390nH	R3220	NOT PLACED		R3505	0662057M62	330
L3504	2462587N51	68nH	L505	2462587Q42	390nH	R3221	0662057M43	51	R3506	0662057B62	3.9
L3511	2462587N44	18nH	PB501	4086470Z01	Tactile Switch	R3222	0662057M70	680	R3507	0662057B62	3.9
L3512	2479990B01	11.03nH	PB502	4086470Z01	Tactile Switch	R3223	0662057V04	12K 1%	R3512	NOT PLACED	
L3513	2479990A02	7.6nH	PB503	4086470Z01	Tactile Switch	R3224	0662057V02	10K 1%	R3513	NOT PLACED	
			PB504	4086470Z01	Tactile Switch	R3226	0662057M64	390	R3519	0680539Z01	0.1

Circuit Ref	Motorola Part No.	Description
R3541	0662057N13	39K
R3542	0662057M92	5600
R3543	0662057M50	100
R3544	0662057A25	100
R3545	0662057A25	100
R3546	0662057N01	12K
R3547	0662057N11	33K
R3548	0662057N07	22K
R3551	0662057M40	39
R3561	0662057N01	12K
R3562	0662057N11	33K
R3563	0662057N33	270K
R3564	0662057N35	330K
R3565	NOT PLACED	
R3566	NOT PLACED	
R3569	0662057M92	5600
R3570	0662057M98	10K
R3571	0662057A27	120
R3572	0662057A27	120
R3573	0662057A27	120
R370	NOT PLACED	
R3701	0662057M50	100
R3702	NOT PLACED	
R3703	0662057M54	150
R3704	0662057M54	150
R3705	0662057N11	33K
R371	0662057N23	100K
R372	0662057N28	160K
R3721	0662057M66	470
R3722	0662057M68	560
R3723	0662057M50	100
R3726	NOT PLACED	
R3727	0662057N23	100K
R373	NOT PLACED	
R374	0662057N23	100K
R3741	0662057M50	100
R375	NOT PLACED	
R3751	0662057N30	200K

Circuit Ref	Motorola Part No.	Description
R3752	0662057N29	180K
R376	0662057M01	0
R3761	0662057N15	47K
R3762	NOT PLACED	
R377	0662057N23	100K
R378	0662057N23	100K
R3801	NOT PLACED	
R3802	0662057M50	100
R3803	0662057M58	220
R3804	0662057M98	10K
R3805	0662057N08	24K
R3806	0662057M34	22
R3807	NOT PLACED	
R3808	0662057M26	10
R3811	0662057M50	100
R3812	NOT PLACED	
R3816	0662057M74	1000
R3817	0662057M01	0
R3818	NOT PLACED	
R3821	0662057M58	220
R3822	0662057M42	47
R3823	0662057N11	33K
R3824	0662057N07	22K
R3825	0662057M38	33
R3826	0662057M32	18
R3828	0662057M50	100
R3829	0662057M01	0
R3830	NOT PLACED	
R3831	0662057M98	10K
R3832	0662057N01	12K
R3833	0662057M58	220
R3834	0662057M42	47
R3835	0662057N15	47K
R3836	0662057M98	10K
R400	0662057N15	47K
R401	0662057M01	0
R402	NOT PLACED	
R403	NOT PLACED	

Circuit Ref	Motorola Part No.	Description
R405	0662057M01	0
R406	0662057N20	'75K
R407	0662057N19	68K
R408	NOT PLACED	
R409	0662057M98	10K
R410	0662057N23	100K
R411	0662057M98	10K
R413	0662057M01	0
R414	0662057V34	180K 1%
R415	0662057V26	91K 1%
R416	0662057M98	10K
R418	0662057M01	0
R419	0662057M67	510
R420	0662057B46	10M
R421	0662057M81	2000
R423	0662057N21	82K
R424	0662057N12	36K
R425	0662057N10	30K
R426	0662057N35	330K
R427	0662057M84	2700
R428	0662057M10	2.2'
R429	0662057N20	'75K
R431	0662057N39	470K
R432	0662057N16	51K
R434	0662057M62	330
R435	0662057M81	2000
R436	0662057M01	0
R437	NOT PLACED	
R445	0662057N08	24K
R447	0662057N23	100K
R448	0662057M98	10K
R449	0662057N08	24K
R450	0683962T45	68
R451	0662057N03	15K
R452	0662057N23	100K
R453	NOT PLACED	
R454	NOT PLACED	
R455	NOT PLACED	

Circuit Ref	Motorola Part No.	Description
R456	0662057M01	0
R457	0662057M98	10K
R460	0662057M90	4700
R461	0662057M56	180
R462	0662057M98	10K
R463	0662057M61	300
R471	0662057N06	20K
R472	0662057M93	6200
R473	0662057M26	10
R475	0662057M01	0
R476	0662057N35	330K
R477	0662057M74	1000
R478	0662057M98	10K
R481	0662057N08	24K
R492	0662057M01	0
R498	0662057M98	10K
R499	0662057M98	10K
R501	0662057M70	680
R502	0662057M56	180
R505	0662057M98	10K
R506	0662057N15	47K
RT3301	NOT PLACED	
RT400	0680590Z01	Thermistor 33K
S501	4080710Z09	Frequency Switch
S502	1880619Z02	Volume/on-off Switch
SH3202	2686539Z01	IFIC Shield
SH3203	2686527Z01	Crystal Filter Shield
SH3301	2686081B01	RX Frontend bottom Shield
SH3302	2686081B05	Mixer Shield
SH3303	2686081B06	RX Frontend top Shield
SH3501	2686081B03	Harmonic Filter Shield
SH3502	2686081B04	PA Driver Shield
SH3701	2680511Z01	Synthesizer top Shield
SH3702	2680511Z01	Synthesizer bottom Shield
SH3801	2680513Z01	VCO top shield
SH3802	2680514Z01	VCO Bottom Shield
SH400	2680505Z01	Controller Memory Shield
SH401	2680506Z01	Controller on-off Shield

Circuit Ref	Motorola Part No.	Description
SH402	2680515Z01	Controller Microprocessor Shield
SH403	2680516Z01	Controller Asfic Shield
T3301	2580541Z02	Transformer
T3302	2580541Z02	Transformer
U303	5113818A01	Dual Op Amp
U3201	5102463J58	3.3V Regulator
U3220	5186144B01	IF IC
U3221	5109522E10	Inverter IC
U3501	5185130C65	LDMOS Driver IC
U3502	5185765B26	PCIC
U3503	5185963A15	Temperature Sensor
U3701	5185130C18	LV FRAC-N IC
U3711	5105739X05	5V Regulator
U3801	5105750U54	VCO BUFFER IC
U400	5102463J40	3.3V Regulator
U404	5185130C53	ASFIC CMP IC
U405	NOT PLACED	
U406	*5102463J59	128K X 8 FLASH ROM
U407	*5102463J64	16K X 8 EEPROM
U409	5102226J56	Microprocessor IC
U410	5102463J57	3.3V Regulator
U420	5102463J44	Audio PA
VR3501	4880140L17	Zener Diode
VR432	4805656W08	Zener Diode
VR433	4805656W08	Zener Diode
VR434	4802245J73	Zener Diode 6.8V
VR439	4880140L17	Zener Diode
VR440	NOT PLACED	
VR441	NOT PLACED	
VR442	NOT PLACED	
VR444	NOT PLACED	
VR447	4802245J74	Zener Diode 10V
VR448	4802245J74	Zener Diode 10V
VR449	4802245J74	Zener Diode 10V
VR450	4802245J75	Zener Diode 12V
VR460	4802245J73	Zener Diode 6.8V
VR501	4802245J73	Zener Diode 6.8V

Circuit Ref	Motorola Part No.	Description
VR506	4802245J73	Zener Diode 6.8V
Y3200	9180022M11	44.85MHZ Crystal Filter
Y3201	4802245J84	44.395MHZ Crystal Oscillator
Y3202	9186145B02	455KHZ Discriminator
Y3203	9180469V05	455KHz 6-Pole Ceramic Filter
Y3204	9180469V03	455KHz 6-Pole Ceramic Filter
Y3205	9180468V05	455KHz 4-Pole Ceramic Filter
Y3761	4805875Z04	16.8 MHZ Crystal Oscillator
	8486473Z01	VHF main PC Board

* Motorola Depot Servicing only

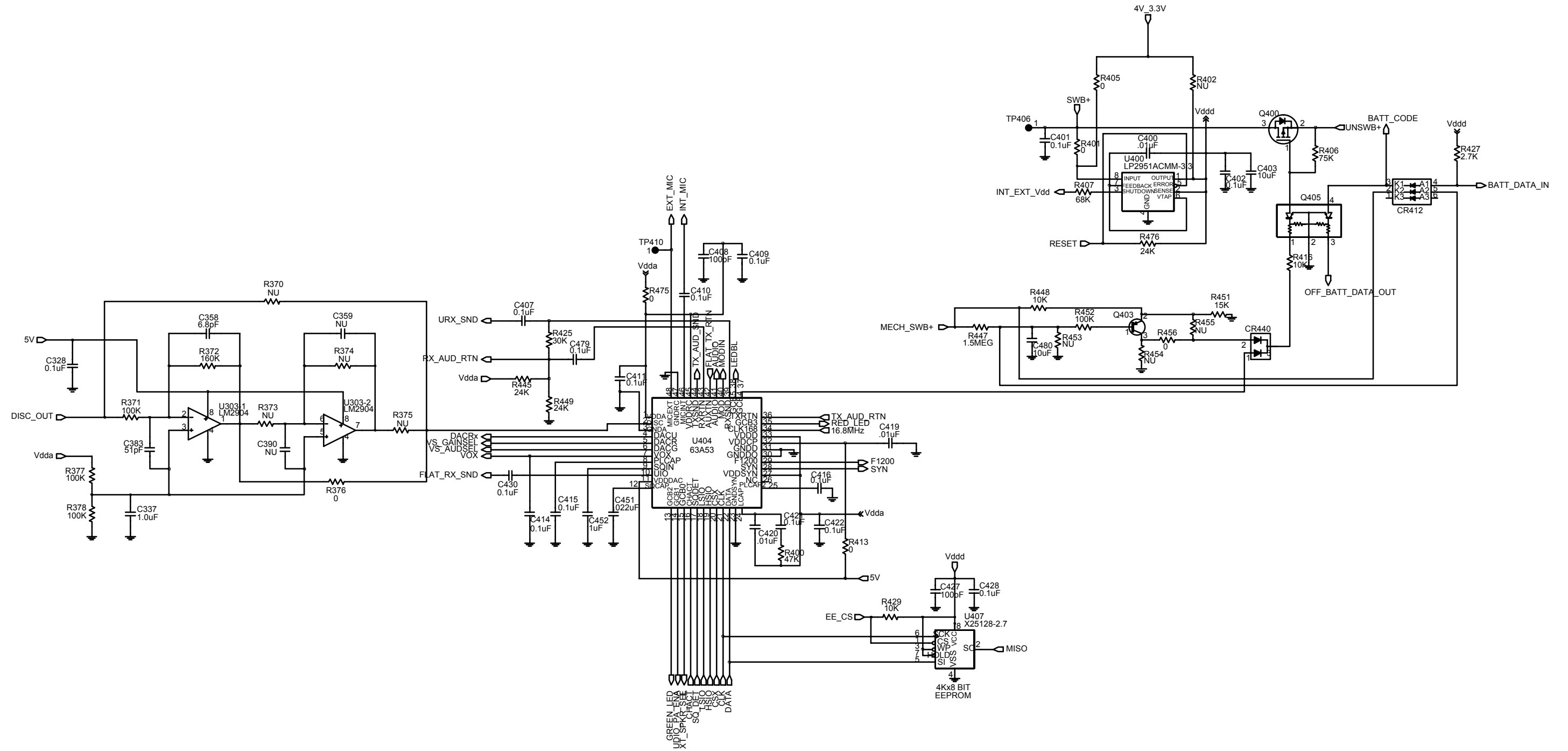
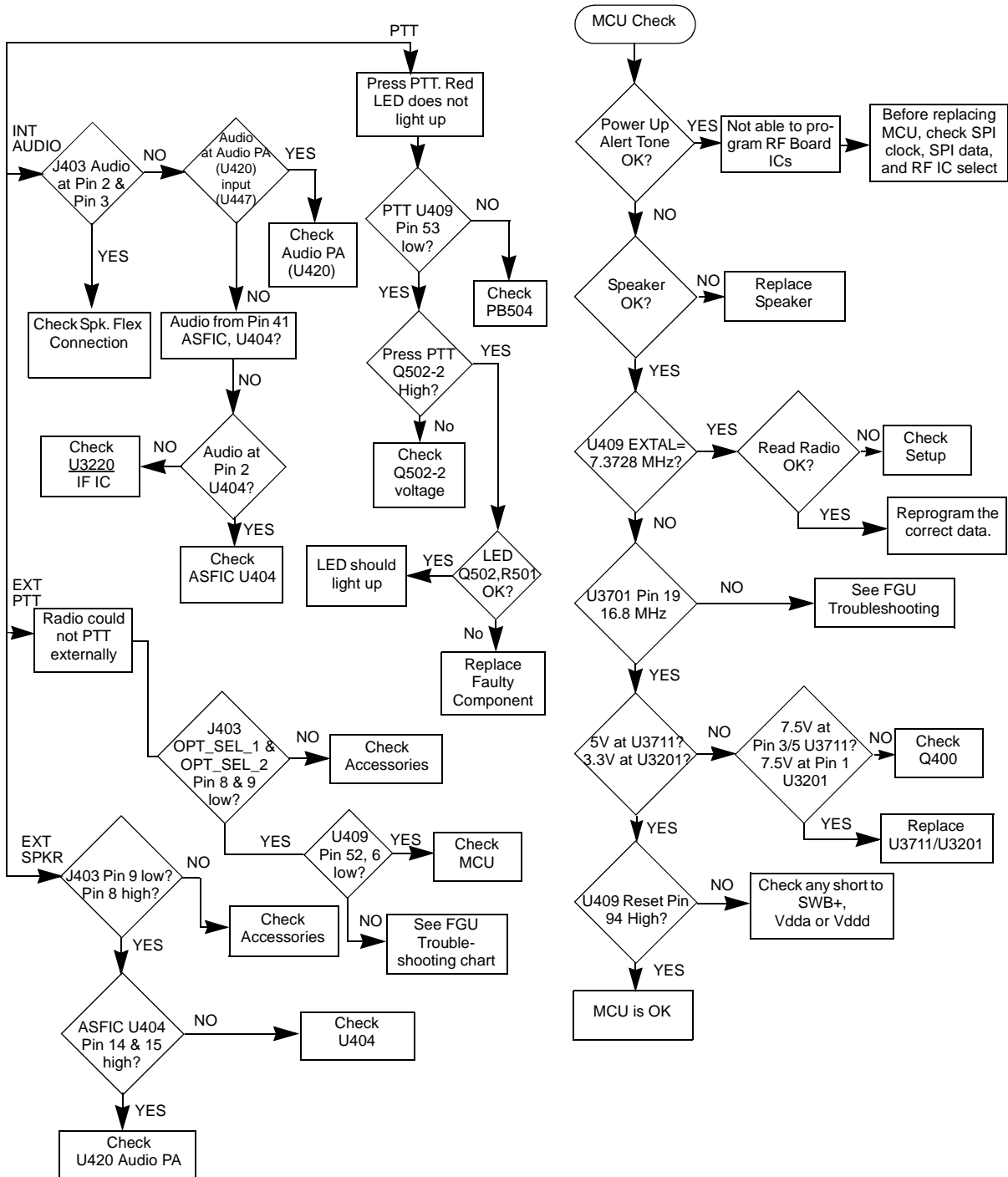

Figure 8-9. Controller ASFIC/ON_OFF Schematic Diagram

Chapter 9 VHF Troubleshooting Charts

9.1 Troubleshooting Flow Chart for Controller



9.2 Troubleshooting Flow Chart for Receiver (Sheet 1 of 2)

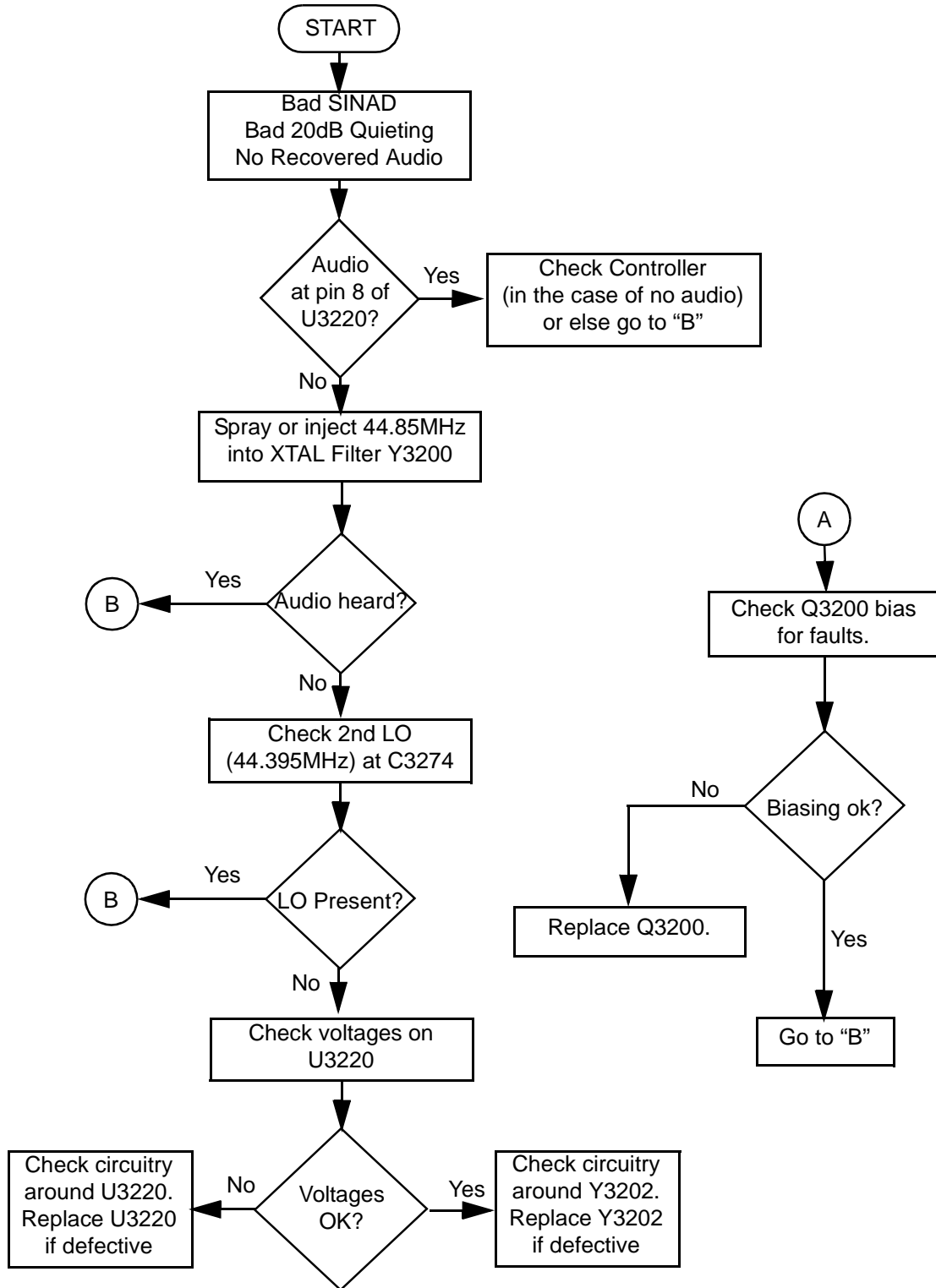

Troubleshooting Flow Chart for Receiver (Sheet 2 of 2)

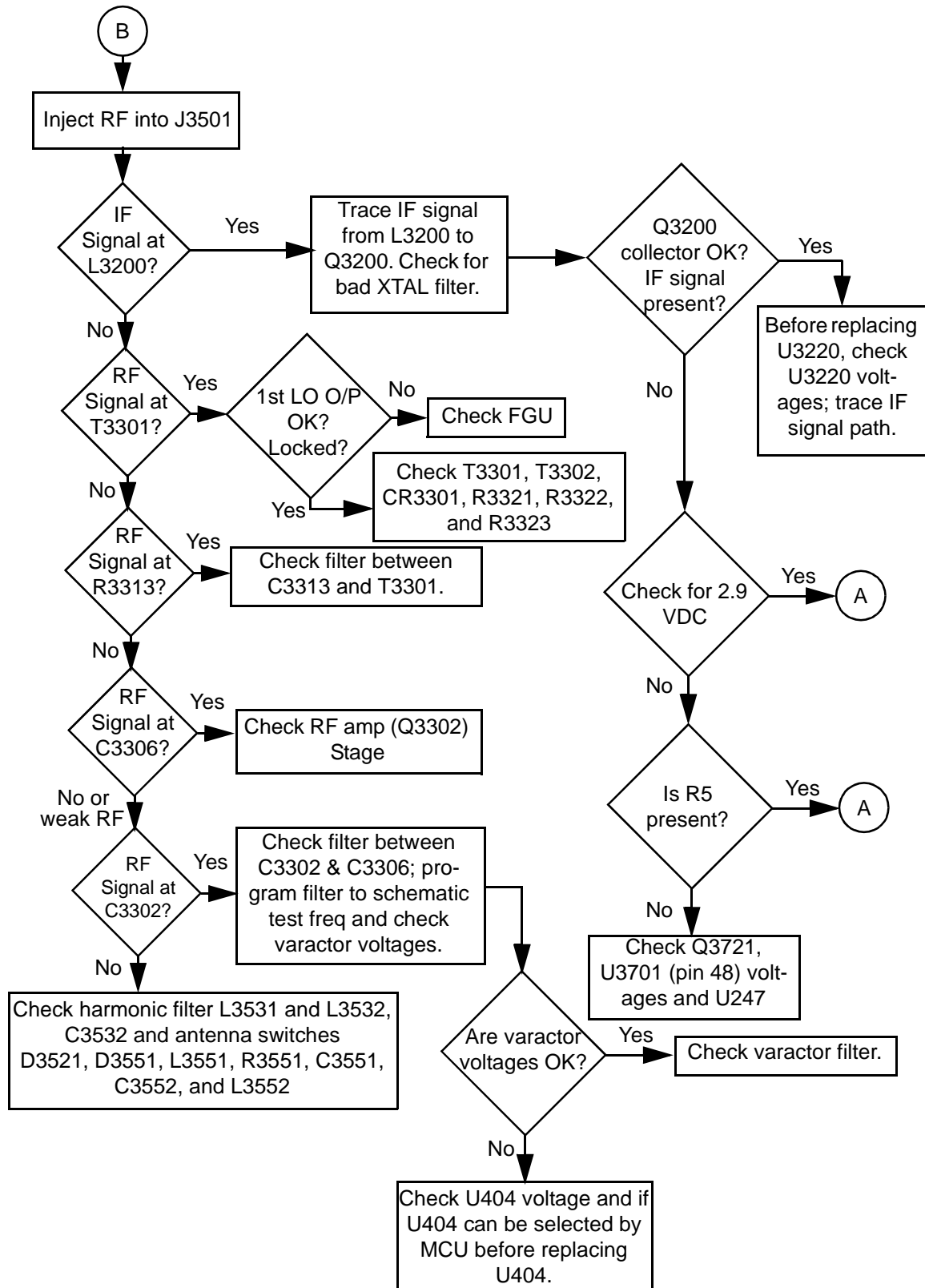

9.3 Troubleshooting Flow Chart for Transmitter

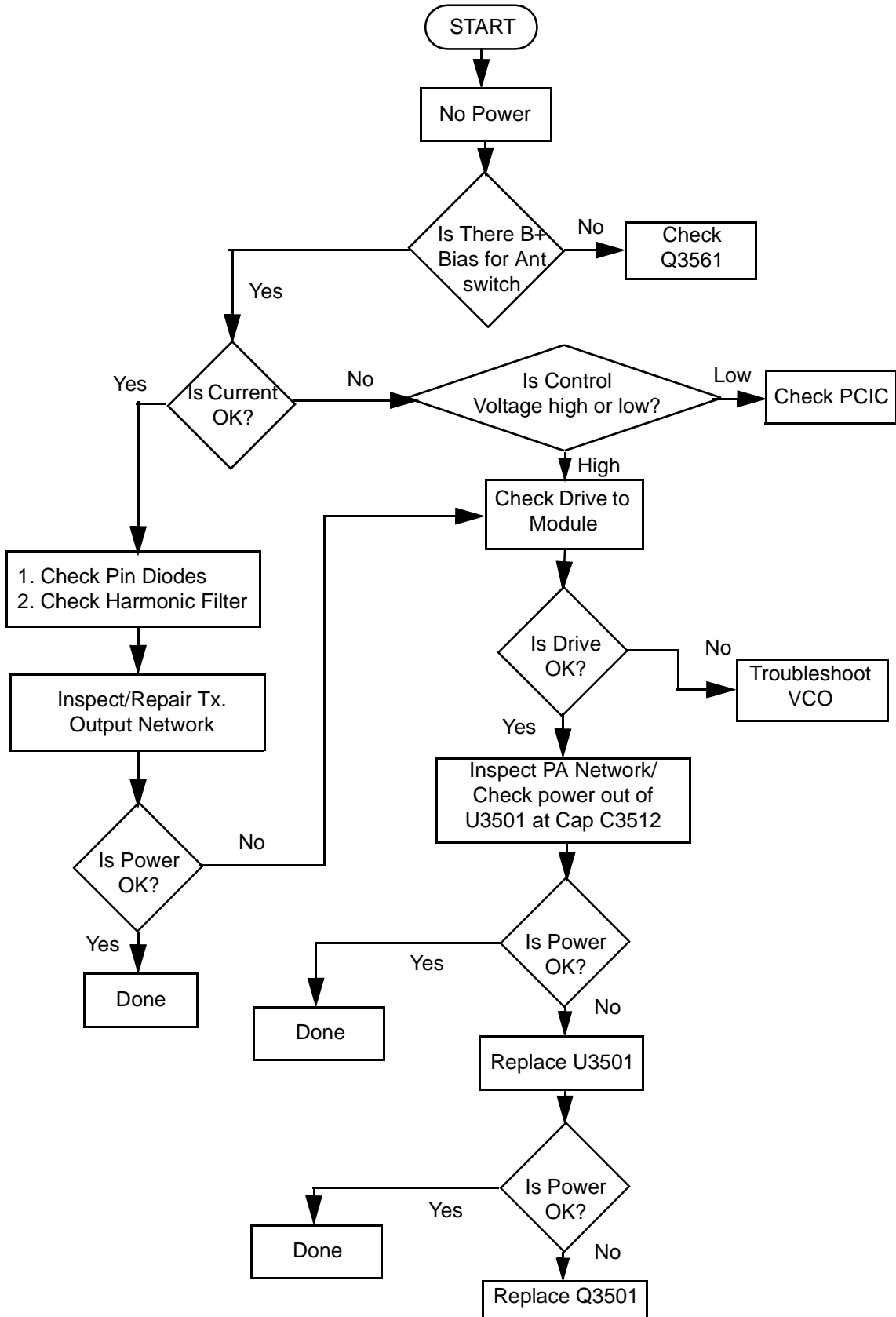

9.4 Troubleshooting Flow Chart for Synthesizer

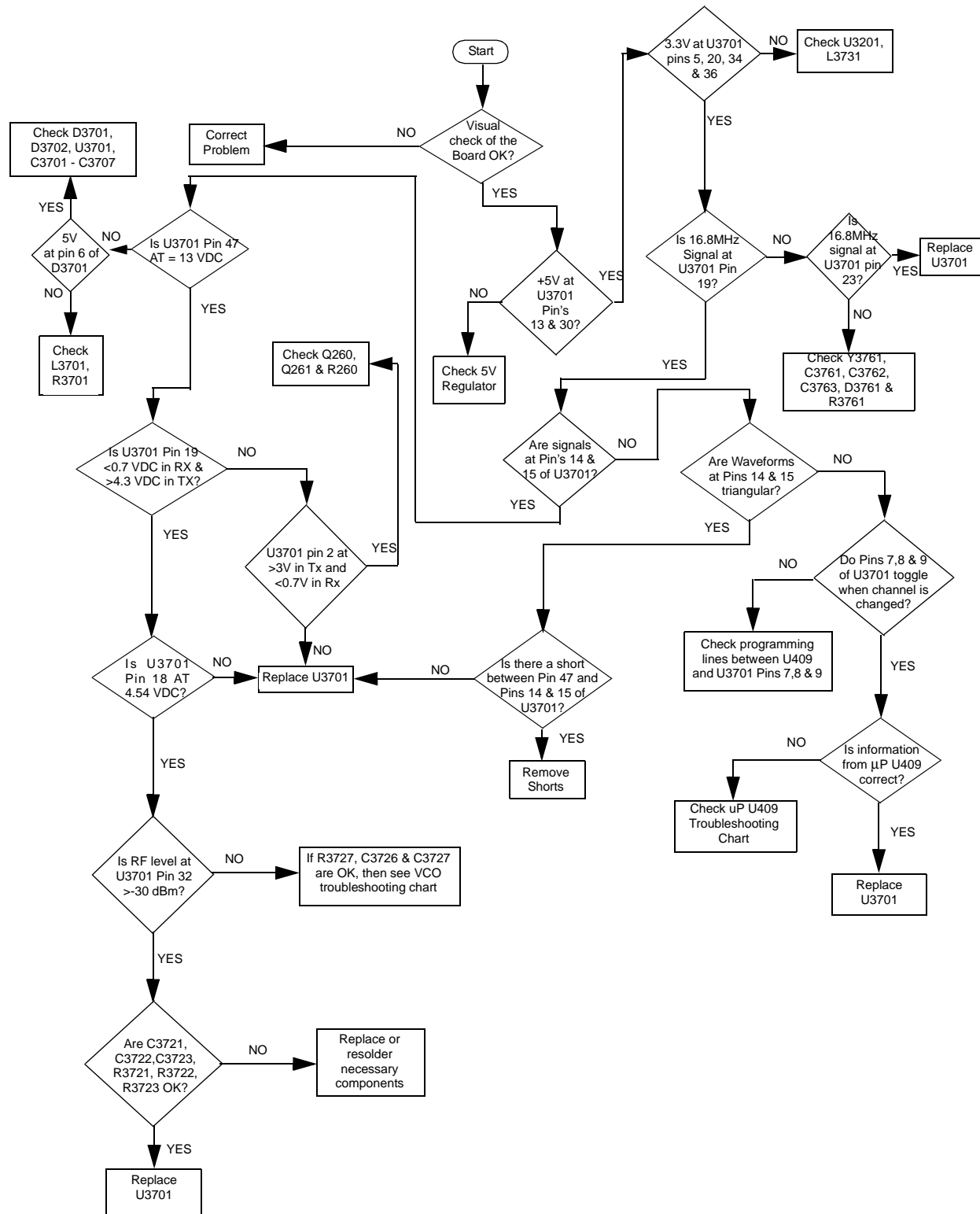

9.5 Troubleshooting Flow Chart for VCO

